

Center of ultrasonic technologies

Electronic generator of ultrasonic frequency

www.u-sonic.ru, www.u-sonic.com

Khmelev Vladimir Nikolaevich



Doctor of Technical Sciences, Professor, Honored Inventor of the Russian Federation, Senior Member IEEE. Laureate of the Russian Government Award in the field of science and technology, author of more than 900 scientific publications (including more than 100 patents, more than 20 monographs and textbooks), Deputy Director for Scientific Work of the Biysk Technological Institute of the Altai State Technical University.

+7 9039925120

vnh@u-sonic.ru

Ultrasonic devices

www.u-sonic.ru

Electrical
energy

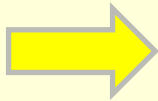

Ultrasonic
devices

Ultrasonic
energy

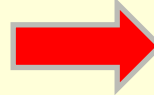

Processing
mediums:
gas, liquid, solid



US devices: convert electrical energy to ultrasonic energy.

Two main elements of ultrasonic devices

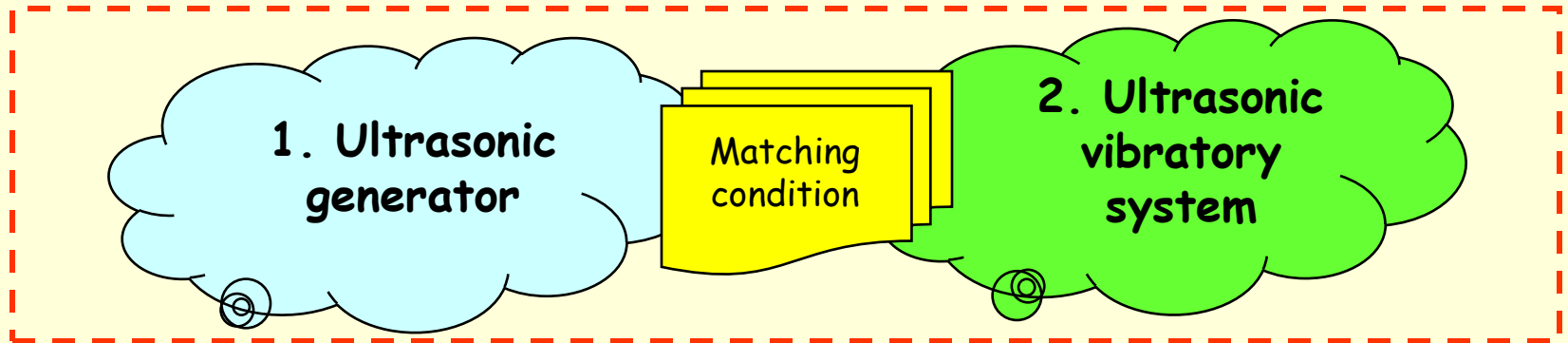

- generation a voltage with a resonance frequency of the vibratory system
- provide enough voltage on the vibratory system
- provide electrical matching generator and vibratory system



- Vibratory system parameters:
1. Resonance frequency
 2. Quality factor
 3. Impedance on resonance frequency
 4. Limit power

Ultrasonic vibratory system

www.u-sonic.ru

Basic elements of vibratory system:

electromechanical transducer

piezoelectric type

magnetostrictive type

elements for mounting

sonotrode

booster

working tools

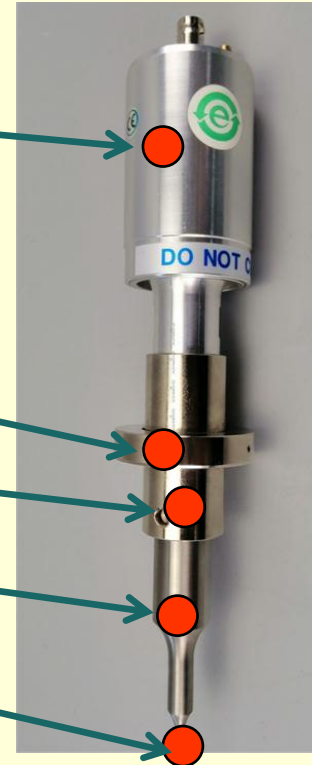

The vibratory system determines the all main parameters of the generators!!!

Ultrasonic electronic generators

www.u-sonic.ru

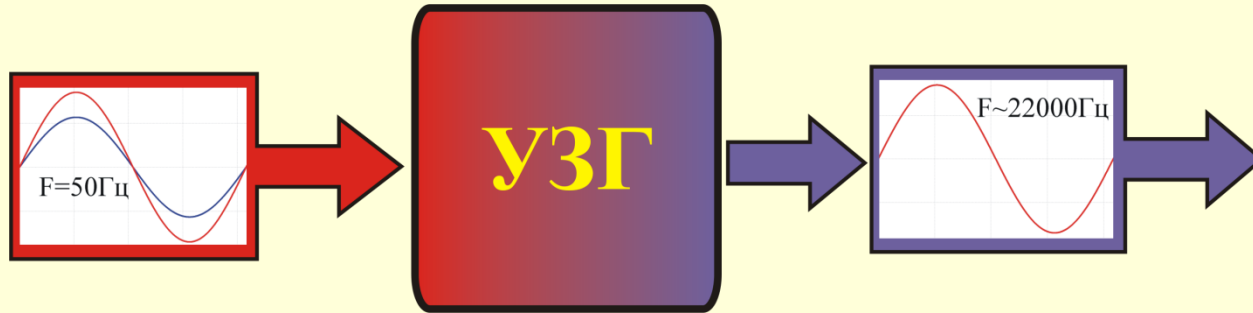

basic requirements to electronic generators :

- required power reserve.
- frequency reserve.
- power control.
- frequency control.
- optimal matching to vibratory system.
- electrical and thermal protect system.
- sinusoidal shape voltage on vibratory system .

Structure of ultrasonic electronic generator

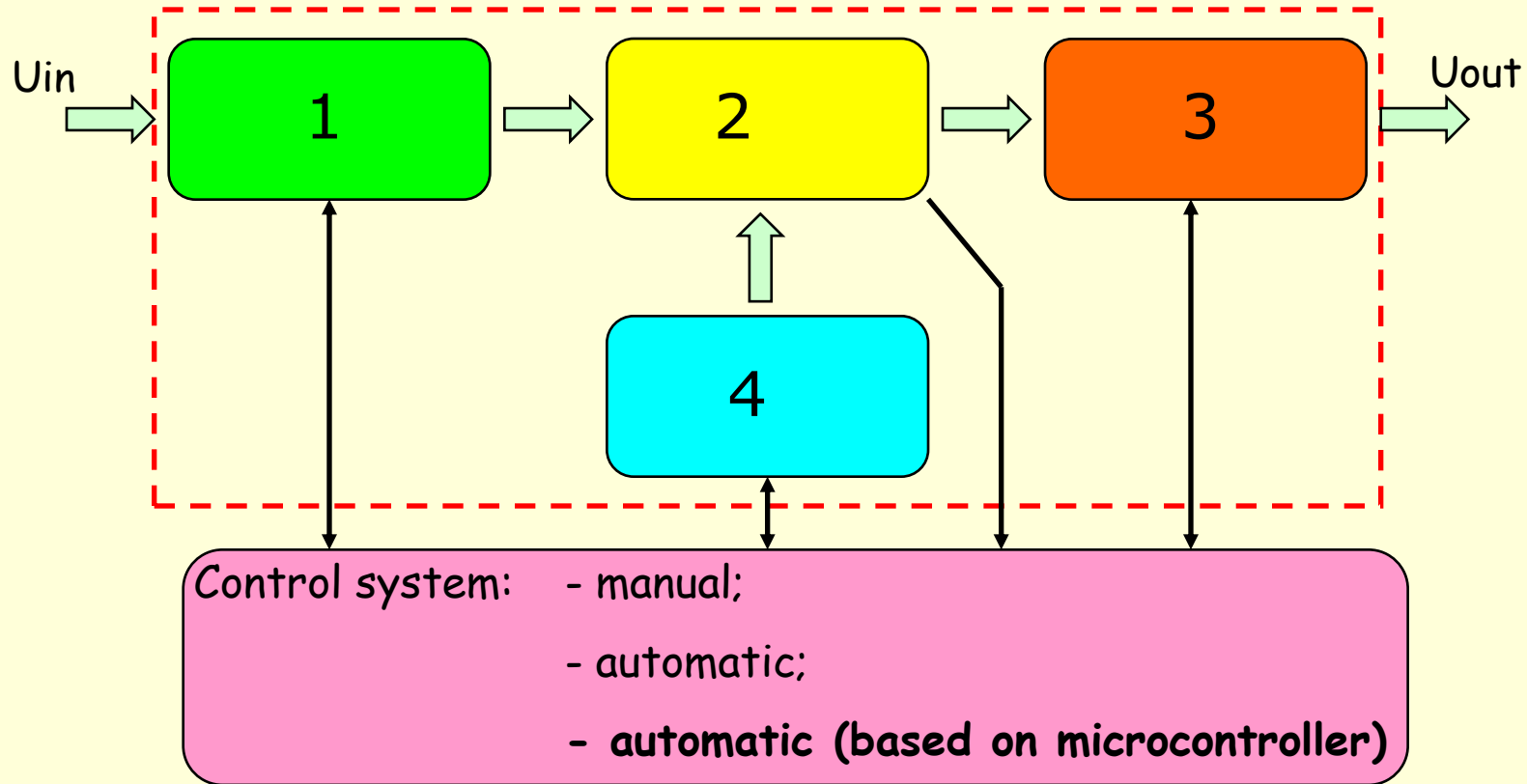

- 1** Input power circuit.
- 2** High-frequency converter.
- 3** Matching circuit.
- 4** Controllable low voltage generator of ultrasonic frequency

U_{in} , U_{out} - input and output voltage of electronic generator

1

Input circuit of ultrasonic generators

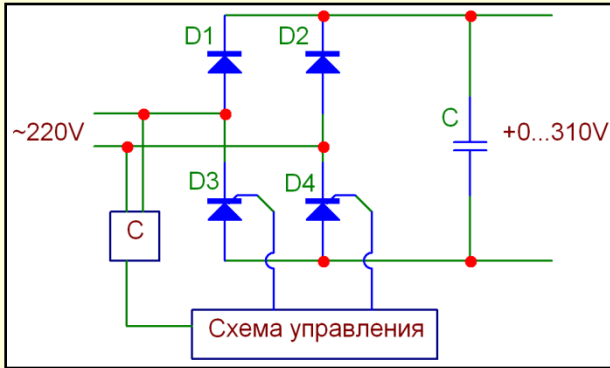

controllable single phase rectifier

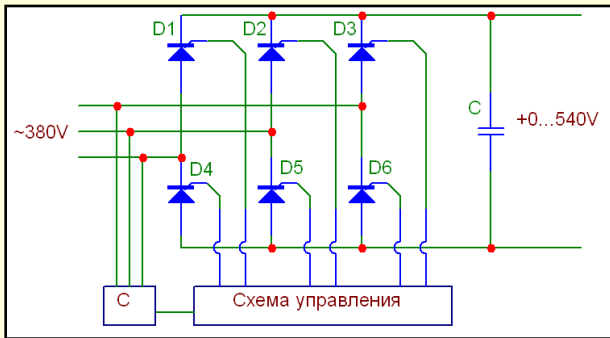
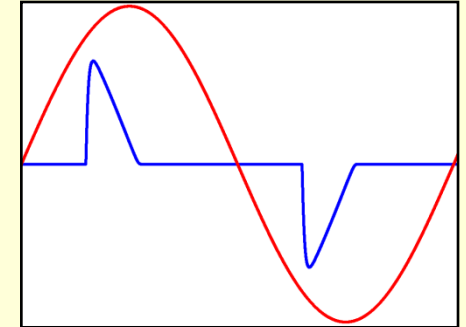

controllable 3 - phase rectifier

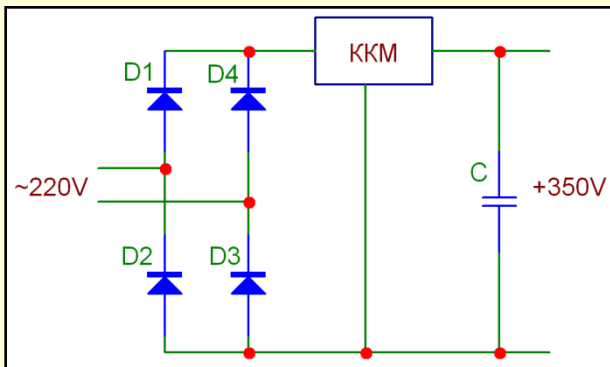
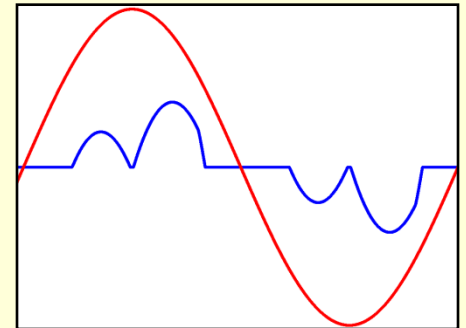

single phase rectifier with PFC circuit

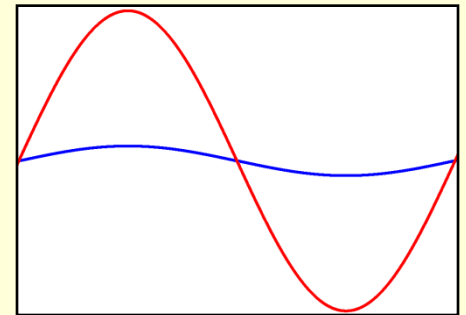

█ - Input voltage
█ - Input current

Half-bridge

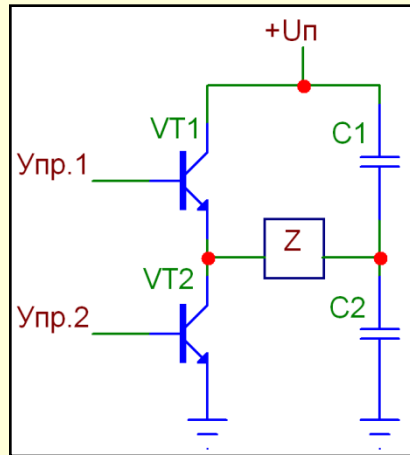

Full bridge

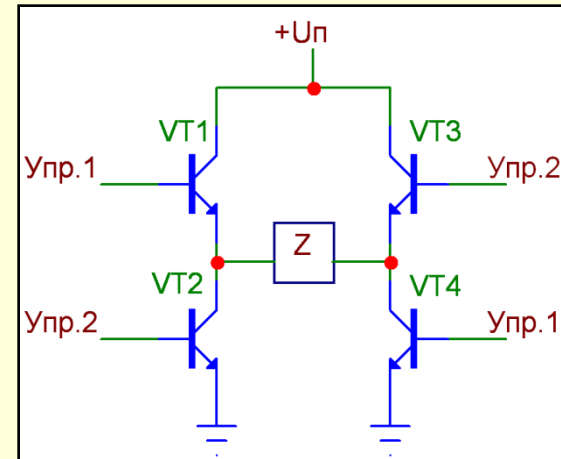

Active element of high-frequency converter

- discrete bipolar transistor
- discrete MOSFET transistor
- discrete IGBT transistor
- IGBT modules
- IPM modules

Z - ultrasonic vibratory system

The matching circuits between generator and vibratory system

www.u-sonic.ru

Transformer matching circuit with adjustable inductor

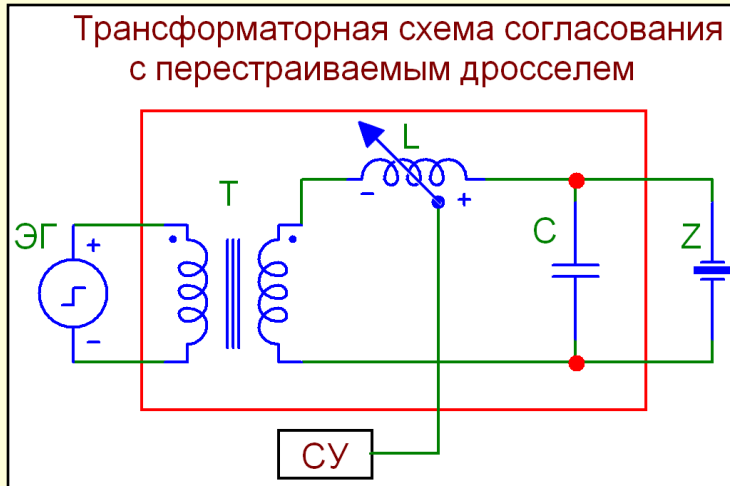

СУ - inductor control system
ЭГ - electronic generator
Z - ultrasonic vibratory system

Inductor with movable core by step motor

Generator «MasterSonic» with manually matching inductor

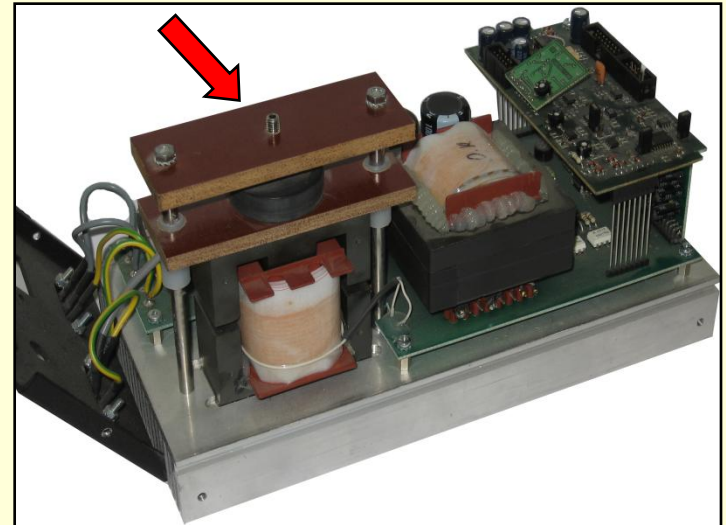

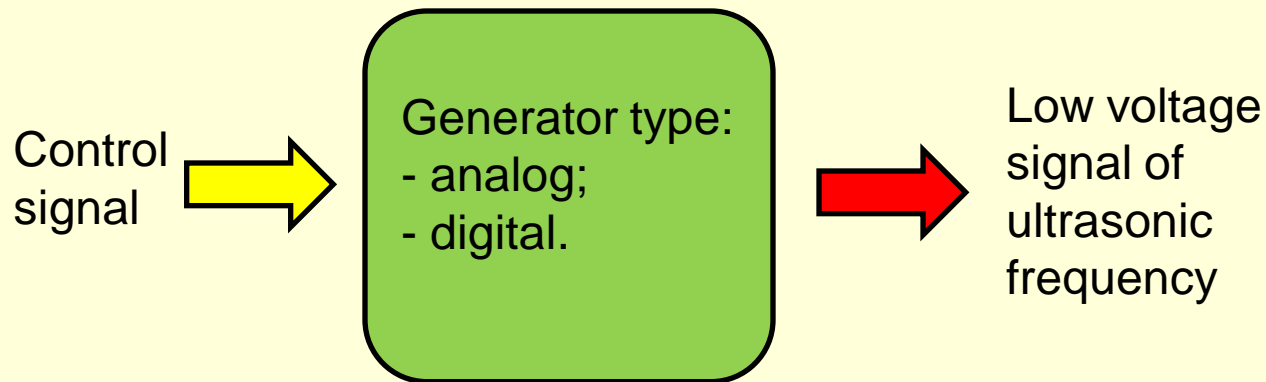
**Basic requirements:**

- ability of frequency adjusting;
- required range of frequency adjustment.



Control system of ultrasonic generator

www.u-sonic.ru

**Microcontroller
(Atmel, **STM**)**

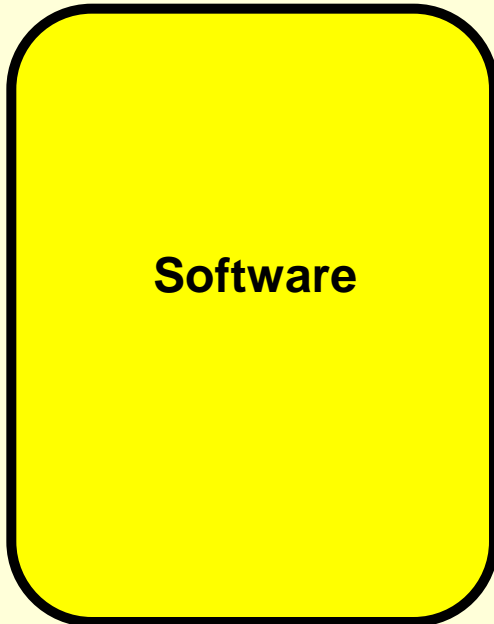

Function of microcontroller:

Power control.

Amplitude control.

Frequency control:

- mode of search for the resonant frequency;
- mode of frequency lost detection;
- restart mode;
- mode of mechanical error detection.

Mode of electrical overload detection.

Communication with control panel.

Communication with external device.

Define work logic of the device as a whole.

Other functions.

Destabilizing factors affecting to ultrasonic devices

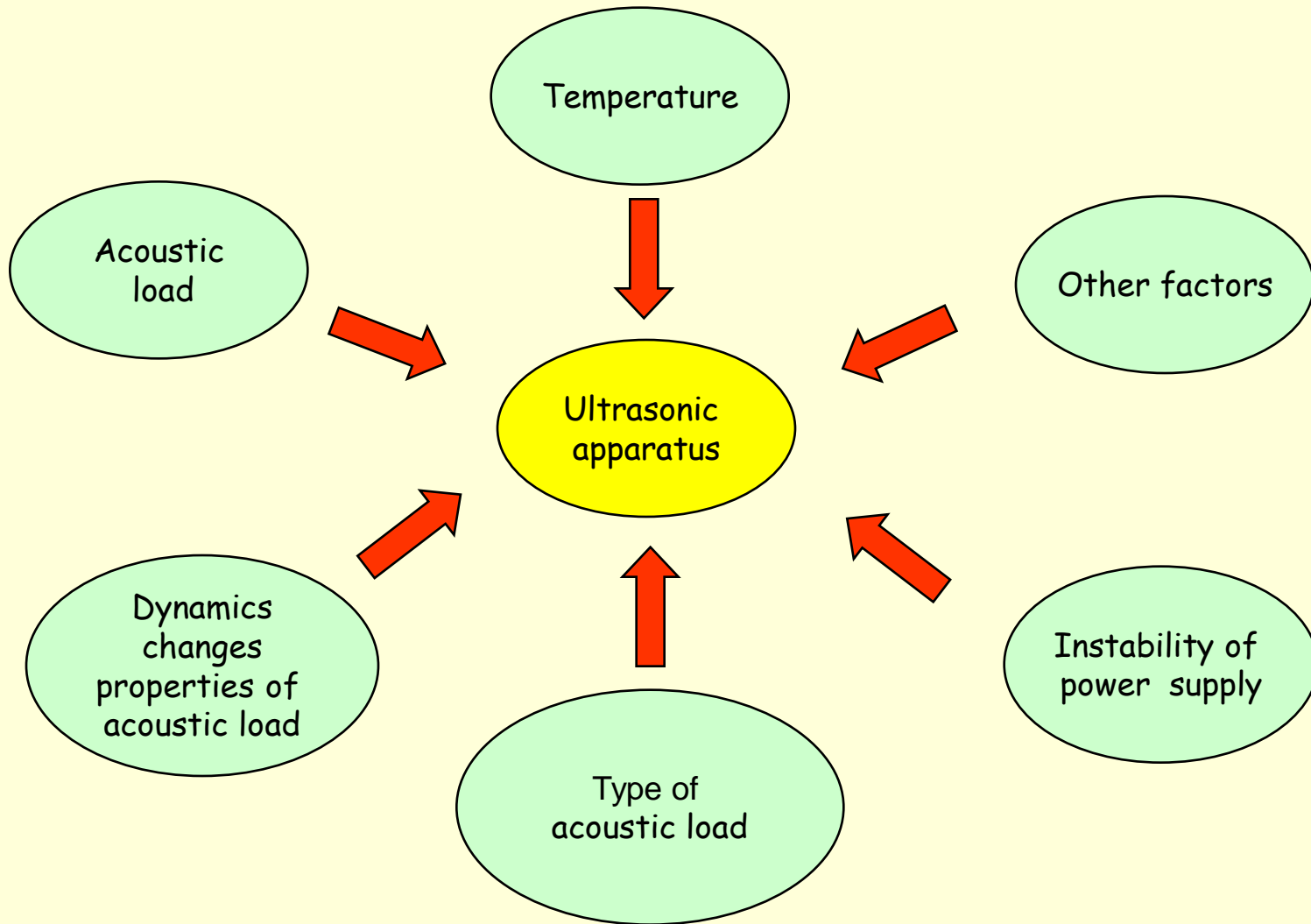

Main system and elements of ultrasonic generators

www.u-sonic.ru

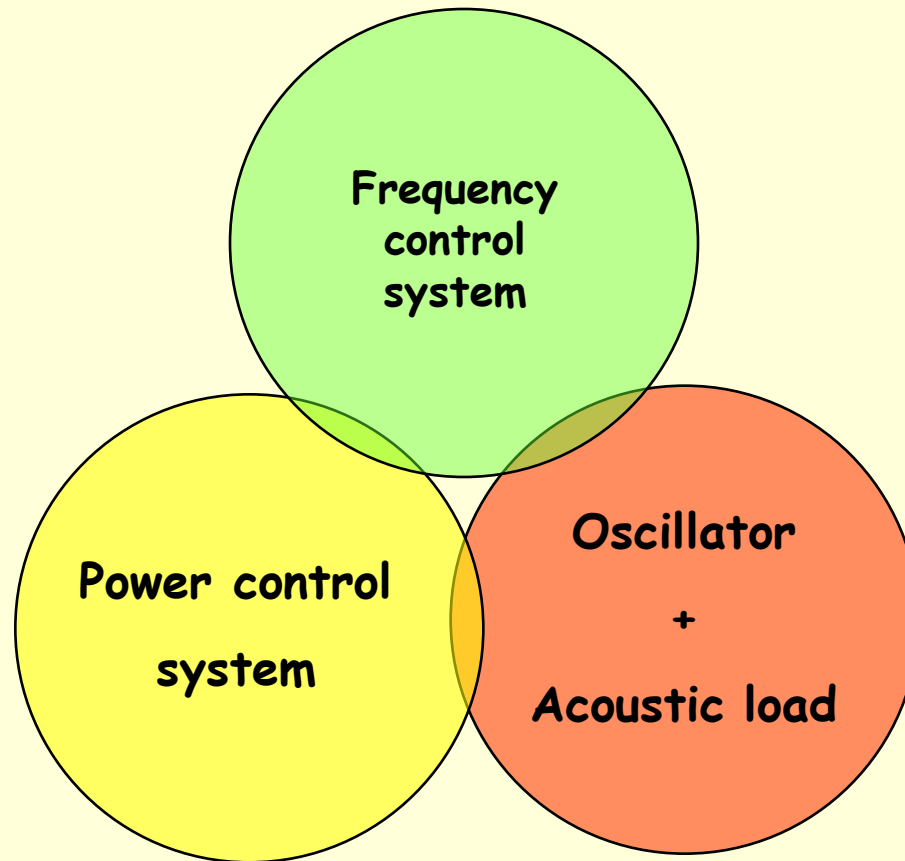

Areas of ultrasonic generators usage

www.u-sonic.ru

Main parameters of ultrasonic generators	Ultrasonic technology		
	Gas environment	Solid environment	Liquid environment
Frequency range: up to 140 KHz. Power range: up to 5 KW.	<ol style="list-style-type: none">1. Foam destruction2. Coagulation3. Drying	<ol style="list-style-type: none">1. Drilling2. Welding of metal3. Welding of plastic4. Cutting5. Metal processing	<ol style="list-style-type: none">1. Extraction2. Emulsification3. Dispersion4. Processing of metal melts5. Acceleration of chemical reactions

Main function of electronic parts of ultrasonic generator

www.u-sonic.ru

Main board
(UVT-1, UVT-2, UVT-3)

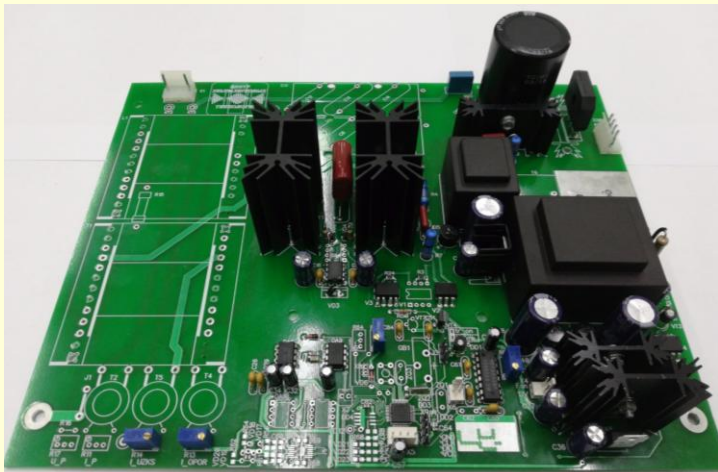

Features:

- Control unit: microcontroller;
- Microcontroller type: stm32f103;
- Amplitude stabilization: yes;
- External control: yes;
- Resonance loss restart system: yes;
- Oscillation system type: piezoelectric;
- Power supply : AC power;
- Automatic frequency control system: yes;
- Vibratory system parameter monitoring system: yes;
- Power measuring: yes;

Types of arrangement of electronic generators

www.u-sonic.ru

Single-board generator

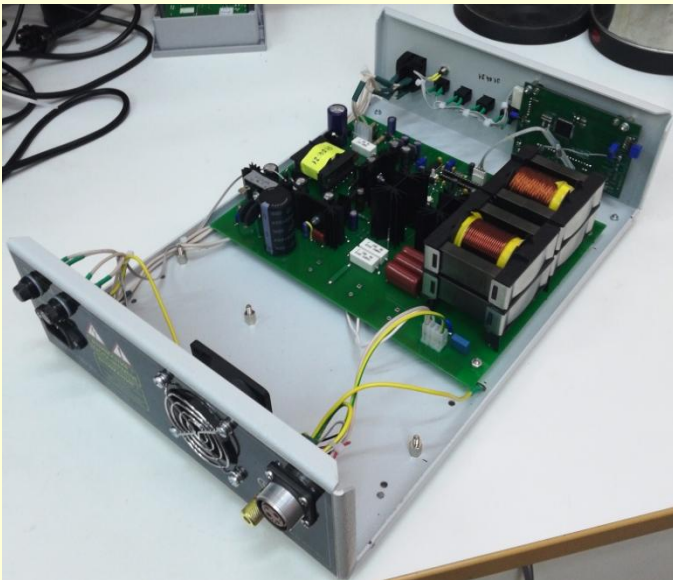

Modular generators

Power supply module

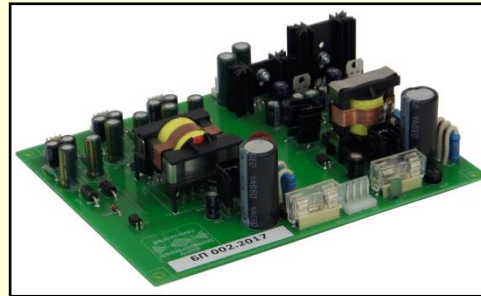

High-frequency inverter

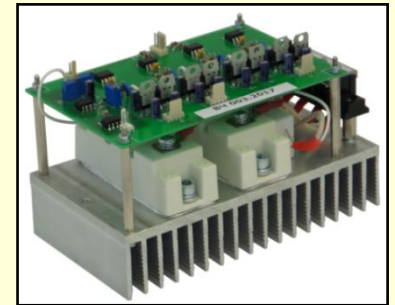

Matching modules

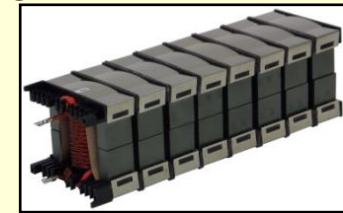

Main board



Power regulator module

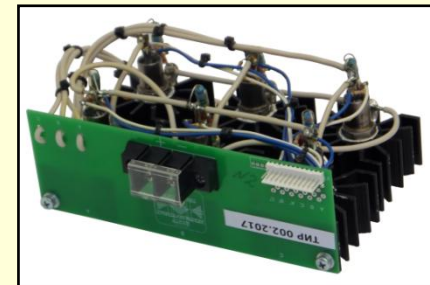

Typical circuit solutions of the main board of electronic generators

Switch-mode step-down power regulator

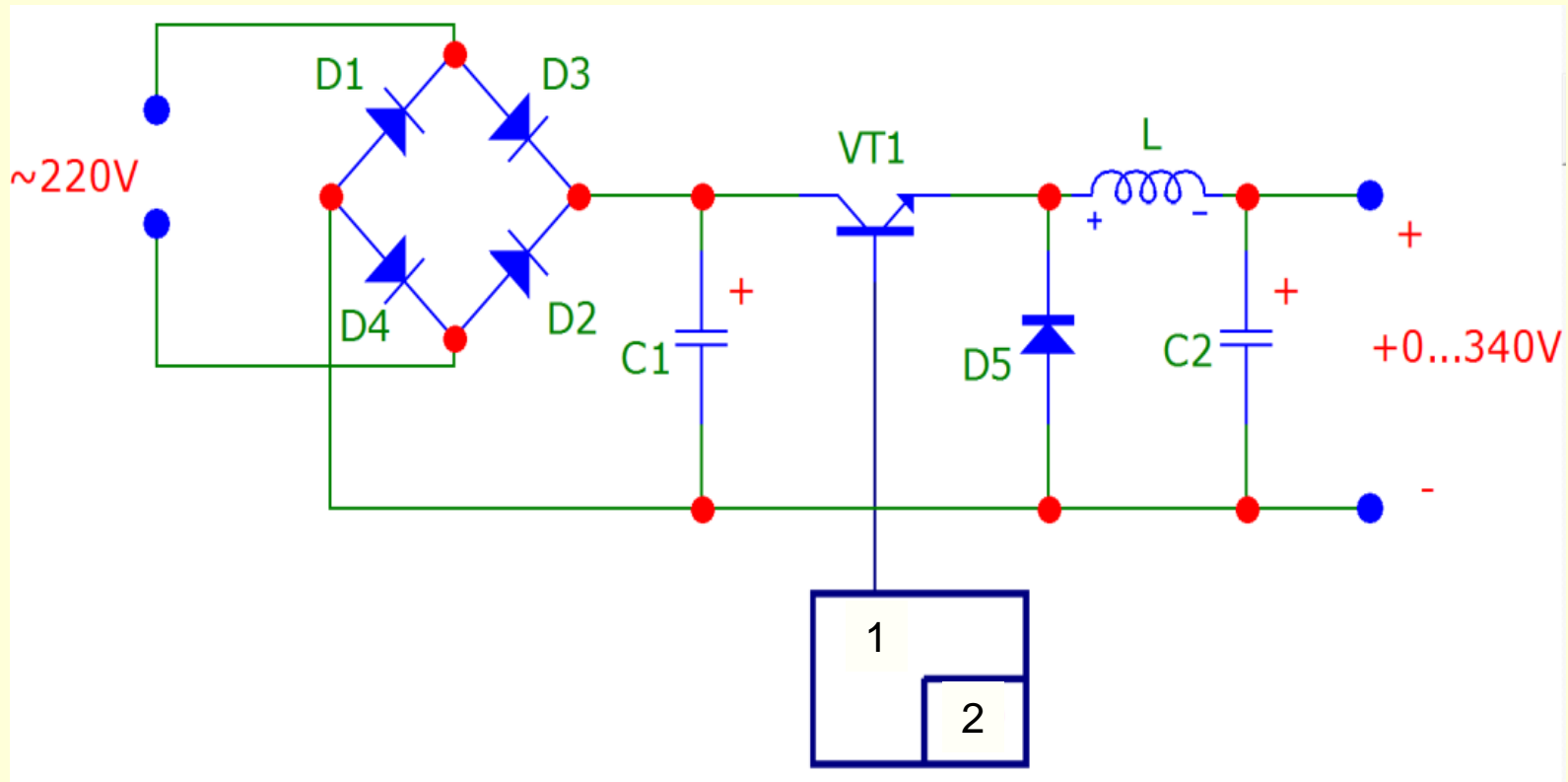

1 – microcontroller;
2 – control program

Circuit of switch-mode step-down power regulator

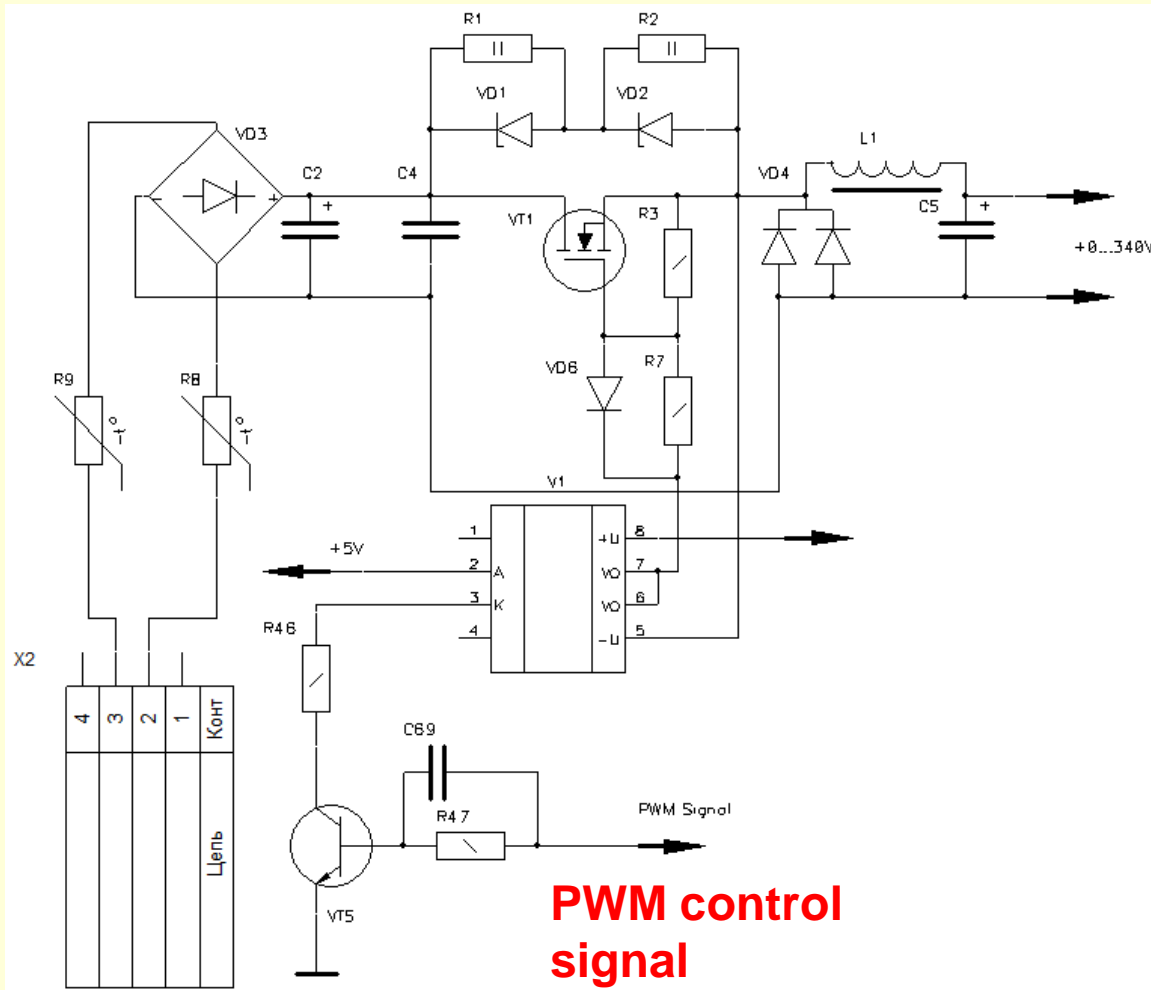

to high-frequency inverter of ultrasonic generator

- frequency of PWM control signal is 60kHz
- APFC factor = 0.8

PWM control signal

to single-phase AC power line

Thyristor power regulator

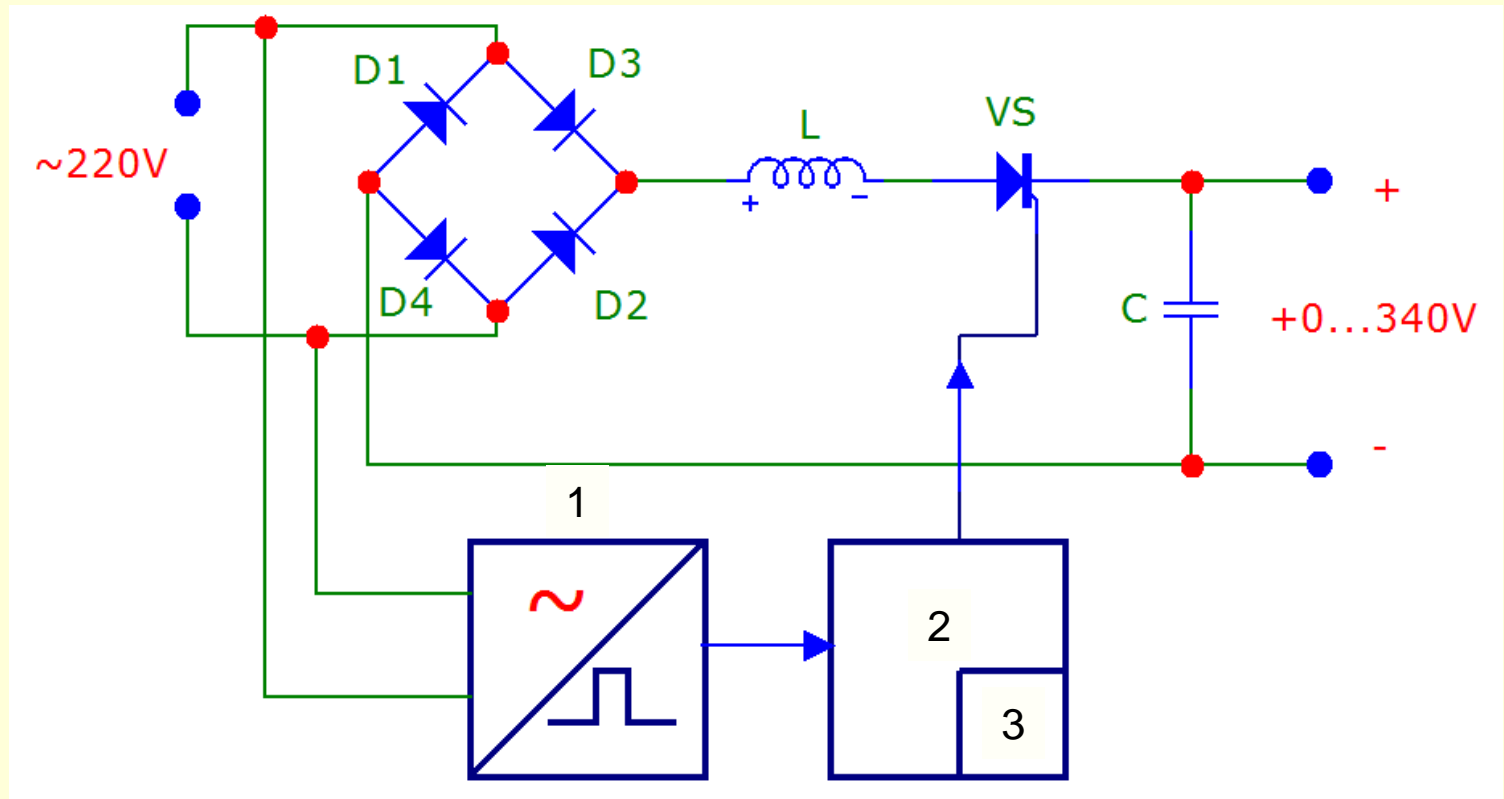

- 1 – zero crossing circuit;
- 2 – microcontroller;
- 3 – control program.

Circuit of single-phase thyristor power regulator

to single-phase AC power line

to high-frequency inverter of ultrasonic generator

Цепь	Конт
1	
2	
3	
4	

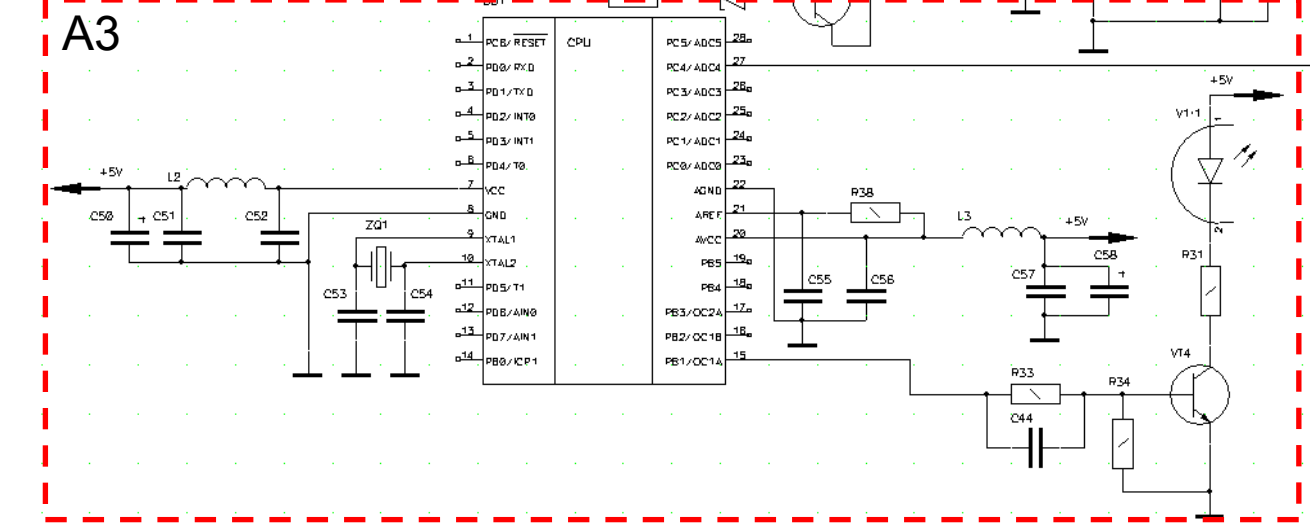
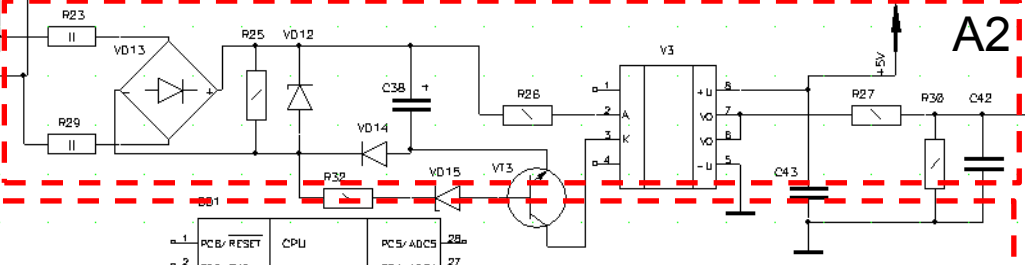
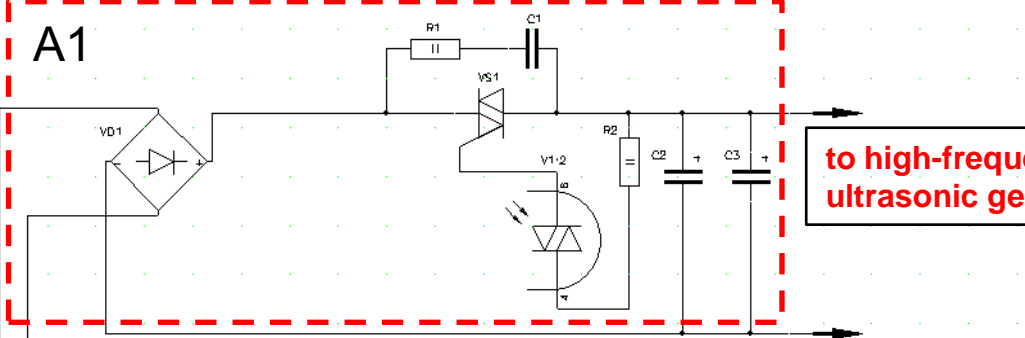

A1 – power line of the regulator;
 A2 – synchro-pulse generation unit;
 A3 - microcontroller unit

Three-phase power regulator thyristor switch unit

www.u-sonic.ru

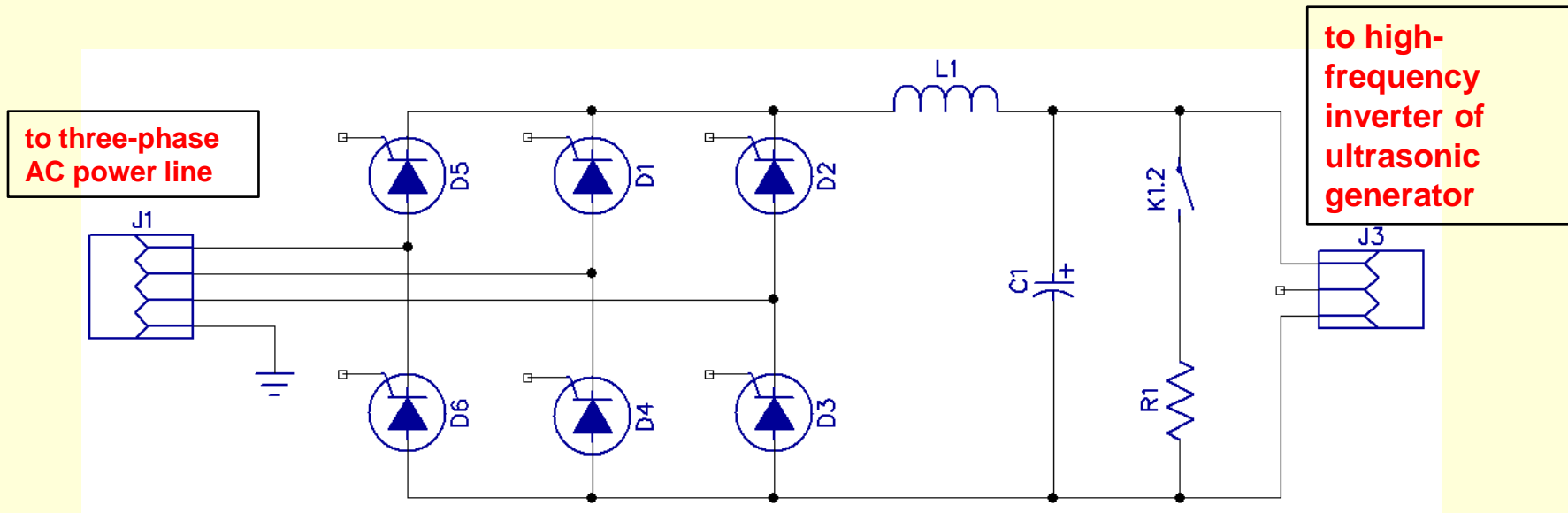

Circuit of control unit of three-phase power regulator

www.u-sonic.ru

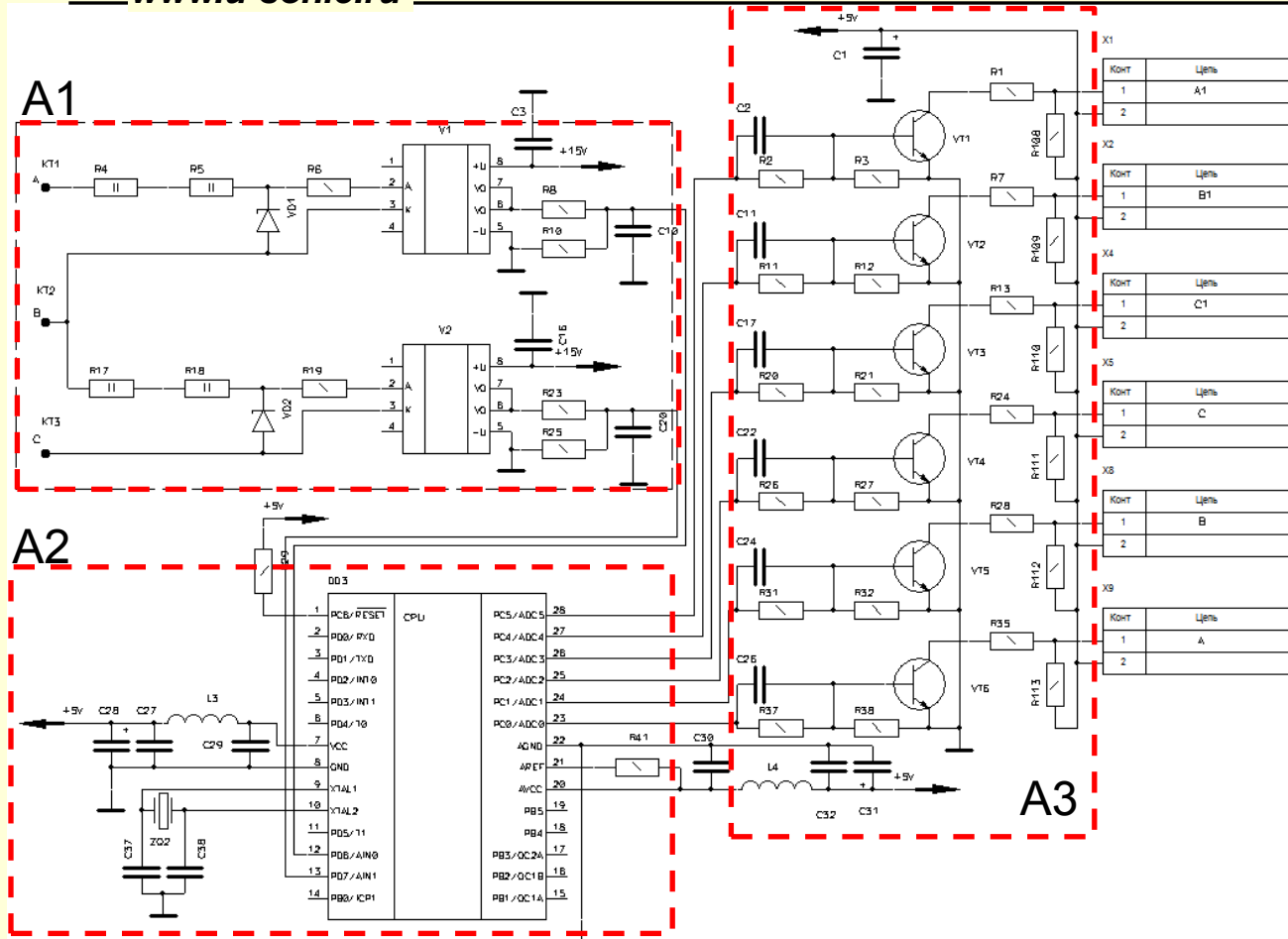

To the thyristor switches of the power regulator

- A1 - synchro-pulse generation unit;
- A2 – microcontroller unit;
- A3 – switches unit

Switch-mode step down regulator with APFC

www.u-sonic.ru

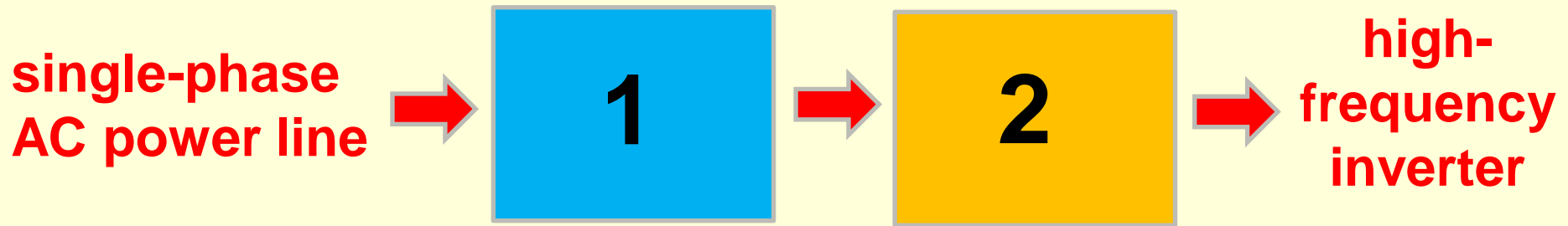

1 – APFC;
2 – Switch-mode step down regulator;

- APFC frequency no more 90 kHz;
- frequency of PWM control signal is 60kHz;
- APFC factor = 0.99.

APFC circuit

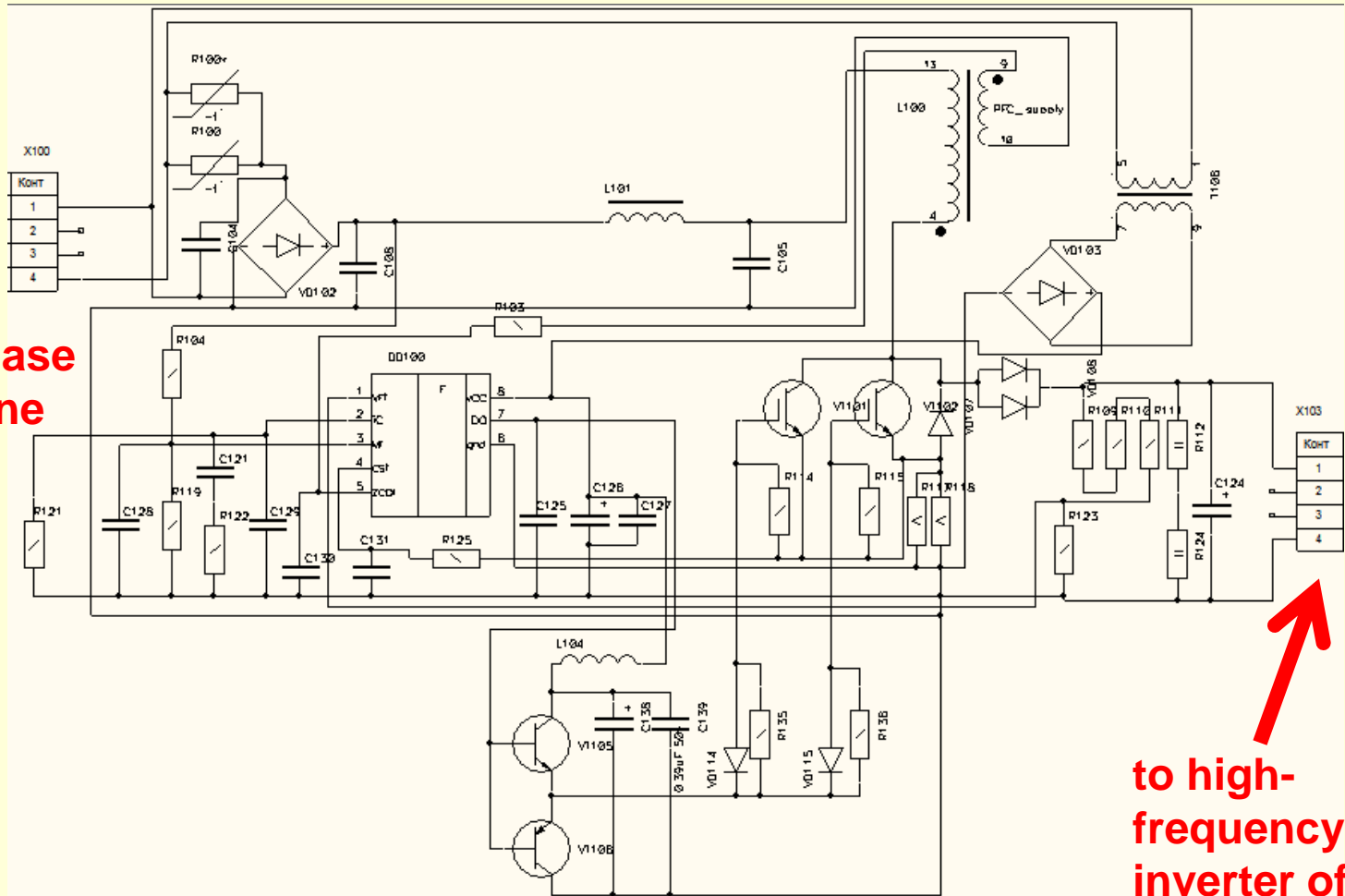

to single-phase AC power line

to high-frequency inverter of ultrasonic generator

Typical circuit of half-bridge inverter with driver

www.u-sonic.ru

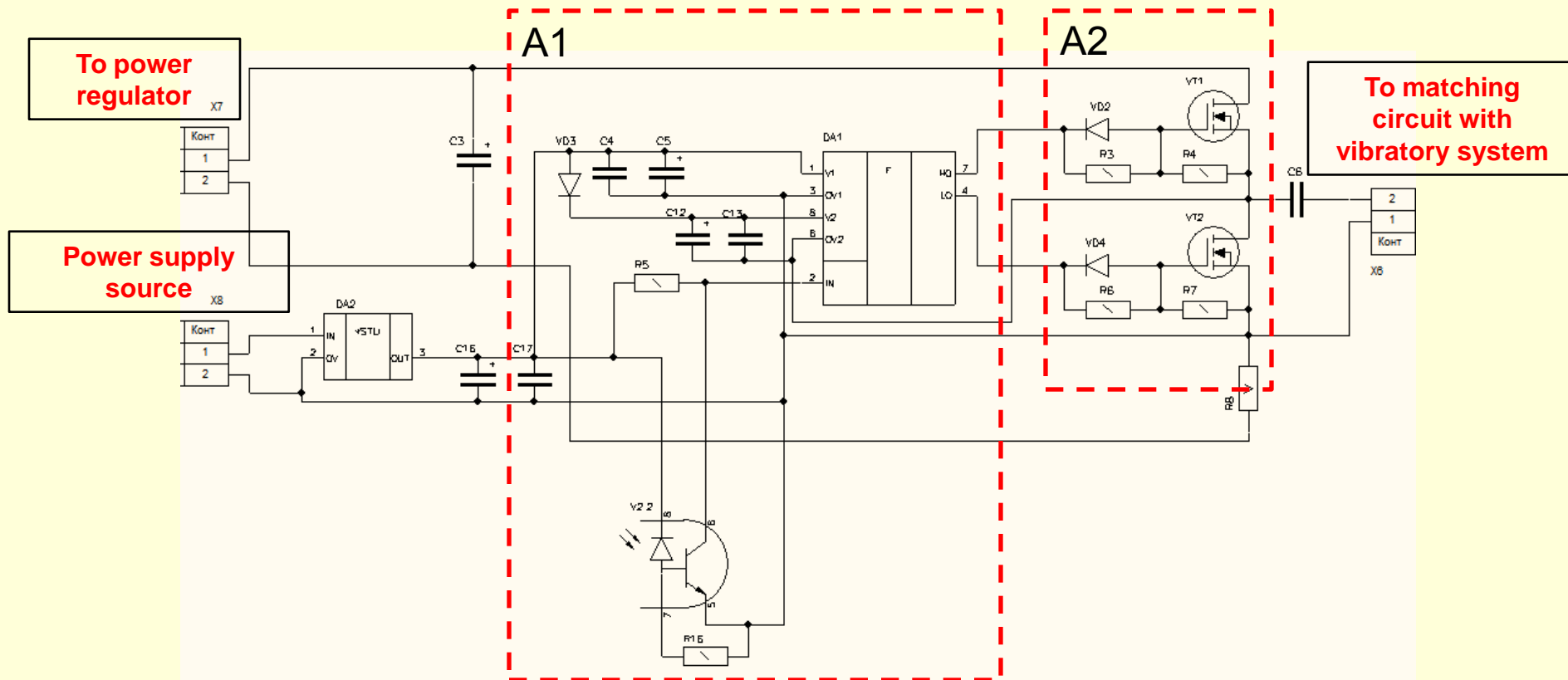

A1 - transistor half-bridge;
A2 - transistor half-bridge driver;

Matching circuit of vibratory system with output of electronic generator

www.u-sonic.ru

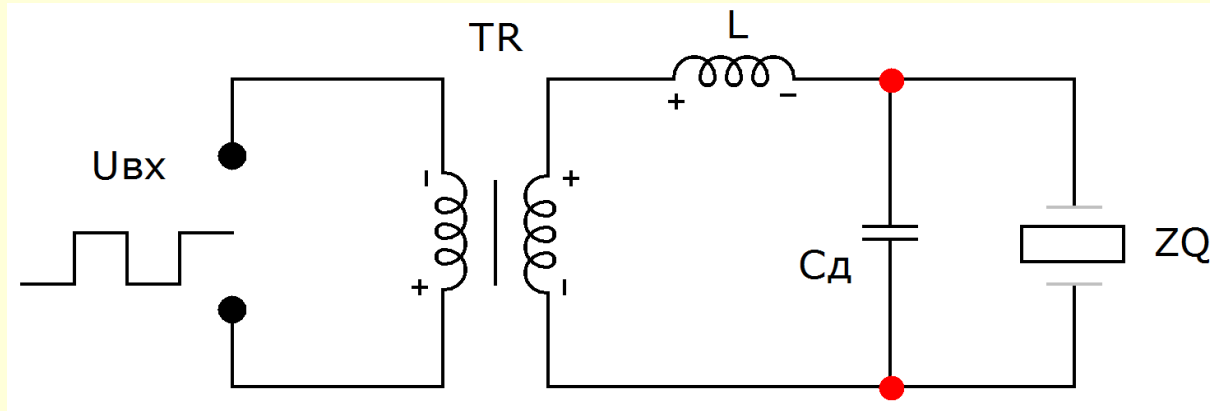

L, C, TR - parts of matching circuit;
 ZQ - transducer of ultrasonic vibratory system;
 F_m - frequency of mechanical resonance;
 F_e - frequency of electrical resonance;

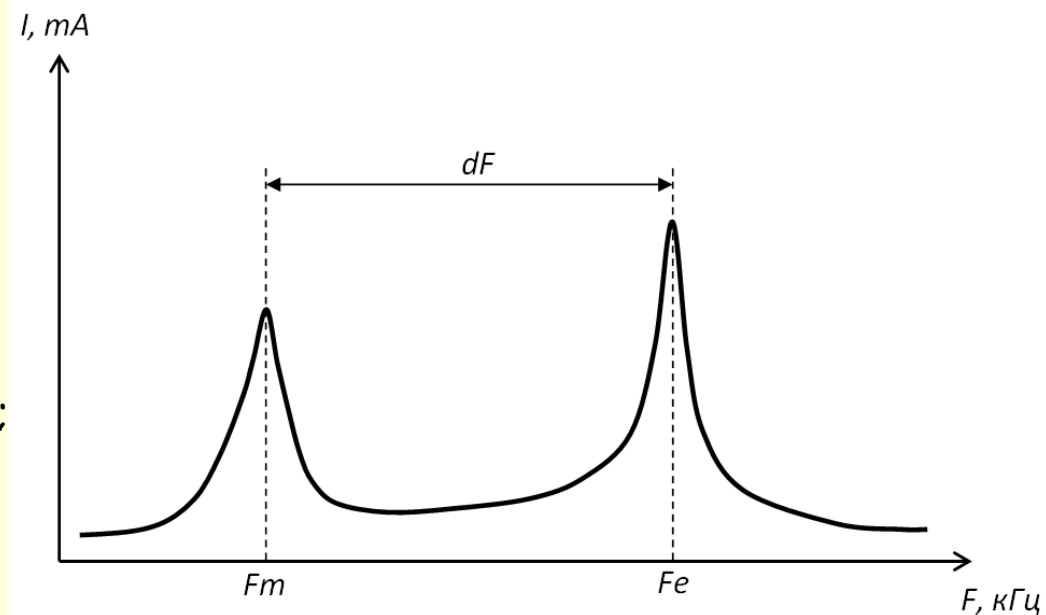

The circuit of feedback signals of the ultrasonic generator

www.u-sonic.ru

to output of high-frequency inverter of ultrasonic generator

To vibratory system

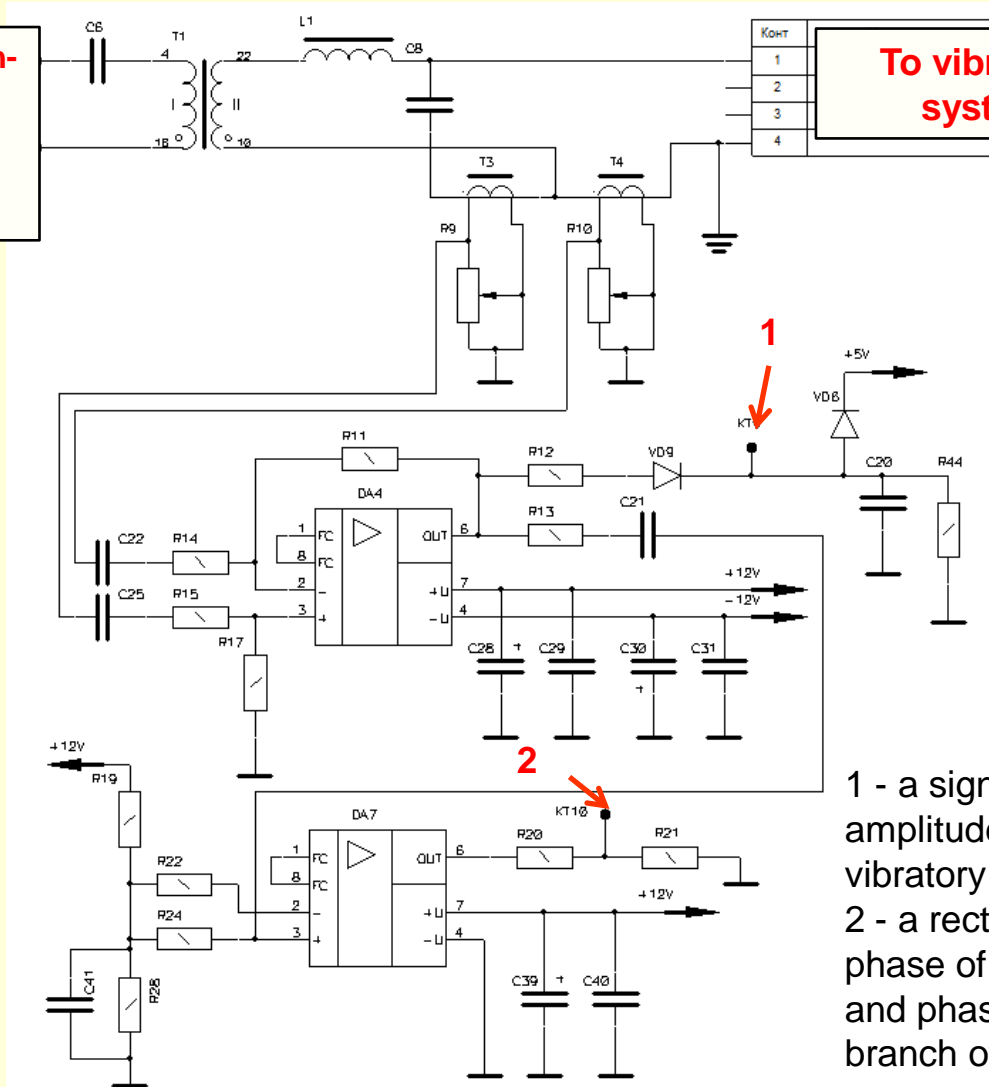

- 1 - a signal proportional to the current amplitude of the mechanical branch of a vibratory system;
- 2 - a rectangular signal, the frequency and phase of which correspond to the frequency and phase of the current of the mechanical branch of a vibratory system;

Monitoring circuit of vibratory system power consumption

www.u-sonic.ru

To vibratory system

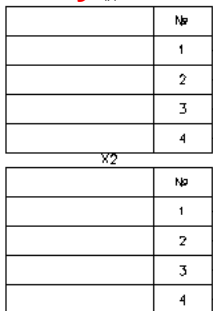

To output of generator

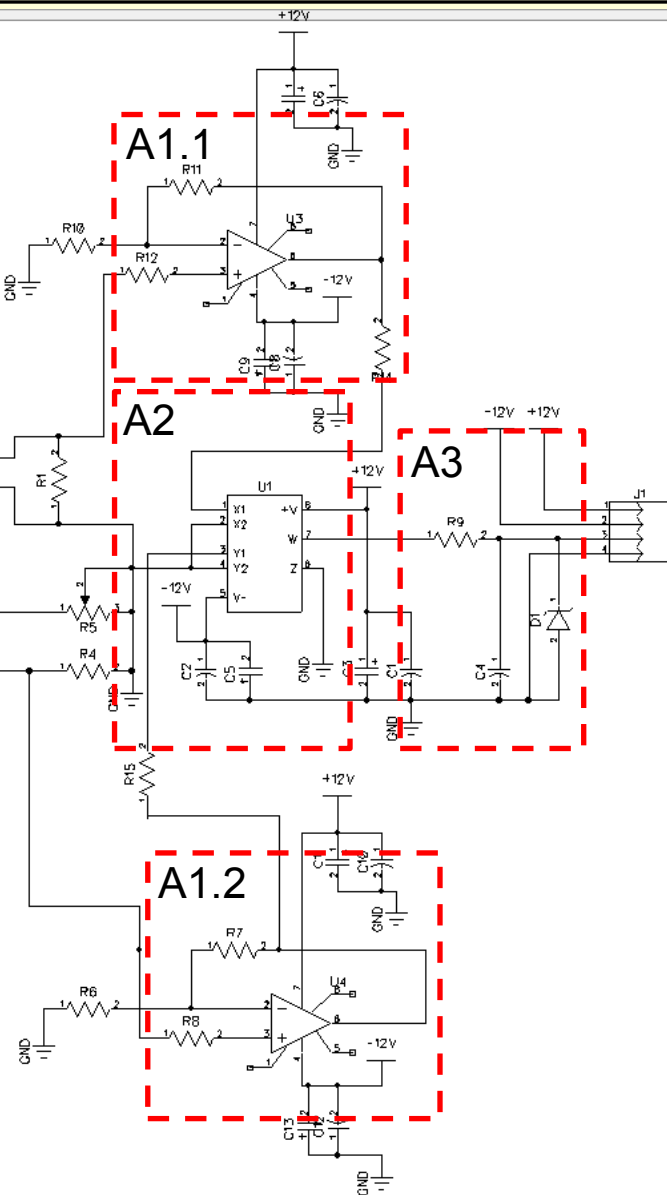

Signal proportional to the measured power

- A1 - normalizing amplifiers;
- A2 - Analog multiplier AD633;
- A3 - Peak detector

Ultrasonic generators

www.u-sonic.ru

Up to 2000W



More 3000W



Up to 500W



Generators combined with actuators

Up to 100W



Monograph about ultrasonic devices

