

**ULTRASONIC INTENSIFICATION OF  
WATER EXTRACTION FROM THE SOIL  
IN ABNORMAL CONDITIONS OF  
EXTRATERRESTRIAL OBJECTS**

Biysk 2022

# Khmelev Vladimir Nikolaevich



**Doctor of Technical Sciences, Professor, Honored Inventor of the Russian Federation, Senior Member IEEE. Laureate of the Russian Government Award in the field of science and technology, author of more than 900 scientific publications (including more than 100 patents, more than 20 monographs and textbooks), Deputy Director for Scientific Work of the Biysk Technological Institute of the Altai State Technical University.**

+7 9039925120  
[vnh@u-sonic.ru](mailto:vnh@u-sonic.ru)

# The purpose of water extraction on the Moon

- Great scientific interest (possible existence of life, conducting experiments impossible on earth);
- Possibility of colonization (extraction of oxygen, cultivation of plants, survival of mankind in case of global catastrophes on Earth);
- Extraction of hydrogen for fuel (launching spacecraft from the Moon for deep space exploration).

The estimated presence of ice at the poles of the Moon based on the results of data processing from the NASA Moon Mineralogy Mapper (M3) instrument (reflective properties, the ability of molecules to absorb infrared light)

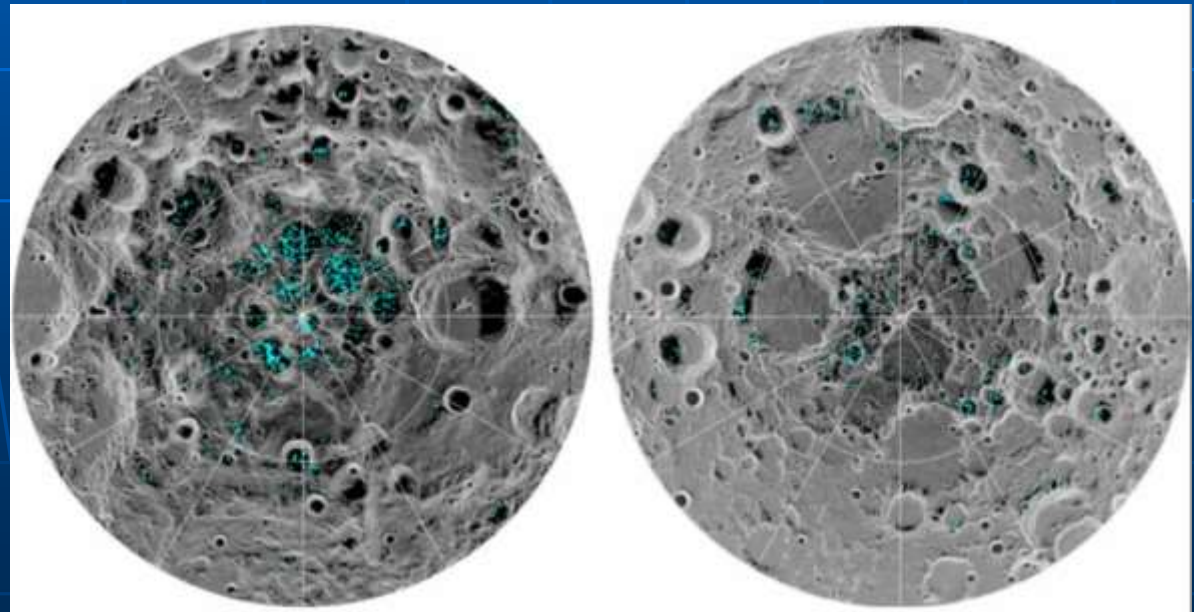

# Detecting and extracting water on the moon: the state of the problem

## Methods of detection and extraction of water

- remote analysis of the moon's surface for water detection;
- sampling of soil on the surface of extraterrestrial objects and further laboratory analysis after delivery to Earth;
- ground capture by a robot in a shaded area of the moon, moving the robot to a sunlit space, then melting ice and evaporation of water due to solar energy and condensation (Kurchatov Institute);
- sublimation of ice or evaporation of water due to heating and then condensation of steam.
- **All these methods are energy-intensive.**

# The way of problem solving

To solve the problem, it is necessary to create a technology for detection and extraction with reduced energy consumption directly on an extraterrestrial object. One of the way is to intensify the process of water extraction due to special energy effects using of

## ultrasonic vibrations.

Ultrasonic vibrations are the vibratory motion of an elastic medium with a frequency of more than 20 kHz. Ultrasonic vibrations can propagate in any materials (transparent and opaque, conductors and dielectrics, etc.). The intensity of ultrasonic vibrations can be 1 kW /cm<sup>2</sup>, which leads to the possibility of implementing and intensifying a variety of technological processes (welding, drilling, impregnation, dissolution, purification, degassing, polymerization, erosion, drying, and many others).



# Ultrasonic effects for intensification of water extraction

Practical implementation of water extraction with ultrasonic exposure

The complexity of introducing ultrasonic vibrations into the ground under low temperatures and pressures

A small reduction of process duration. Its dependence from the type of material, its quantity and particle size

Absent of technical solutions for the implementation of the process in space conditions

No dependence of the efficiency of ultrasonic water extraction on the conditions of ultrasonic exposure

Absent of data on the presence and magnitude of the "threshold value of the intensity of ultrasonic exposure" at which ultrasonic water extraction becomes effective

The impossibility of realization of energetically advantageous ultrasonic exposure mode, but does not exceed the maximum capabilities of modern radiators

Intensify the process of extracting and extracting water from the lunar soil require solving these problems

# Methods of water extraction from extraterrestrial soils



Methods of water extraction  
by ultrasonic exposure

Contact method

Contactless method

The possibility of  
exposure in a  
vacuum

Significant thermal  
effect

Significant exposure area  
in the case of an  
intermediate gas medium

Low wear of the ultrasonic  
radiator

Process of water extraction from extraterrestrial soils  
at various modes of ultrasonic exposure,  
including without phase transition

# Principles of implementation of water extraction

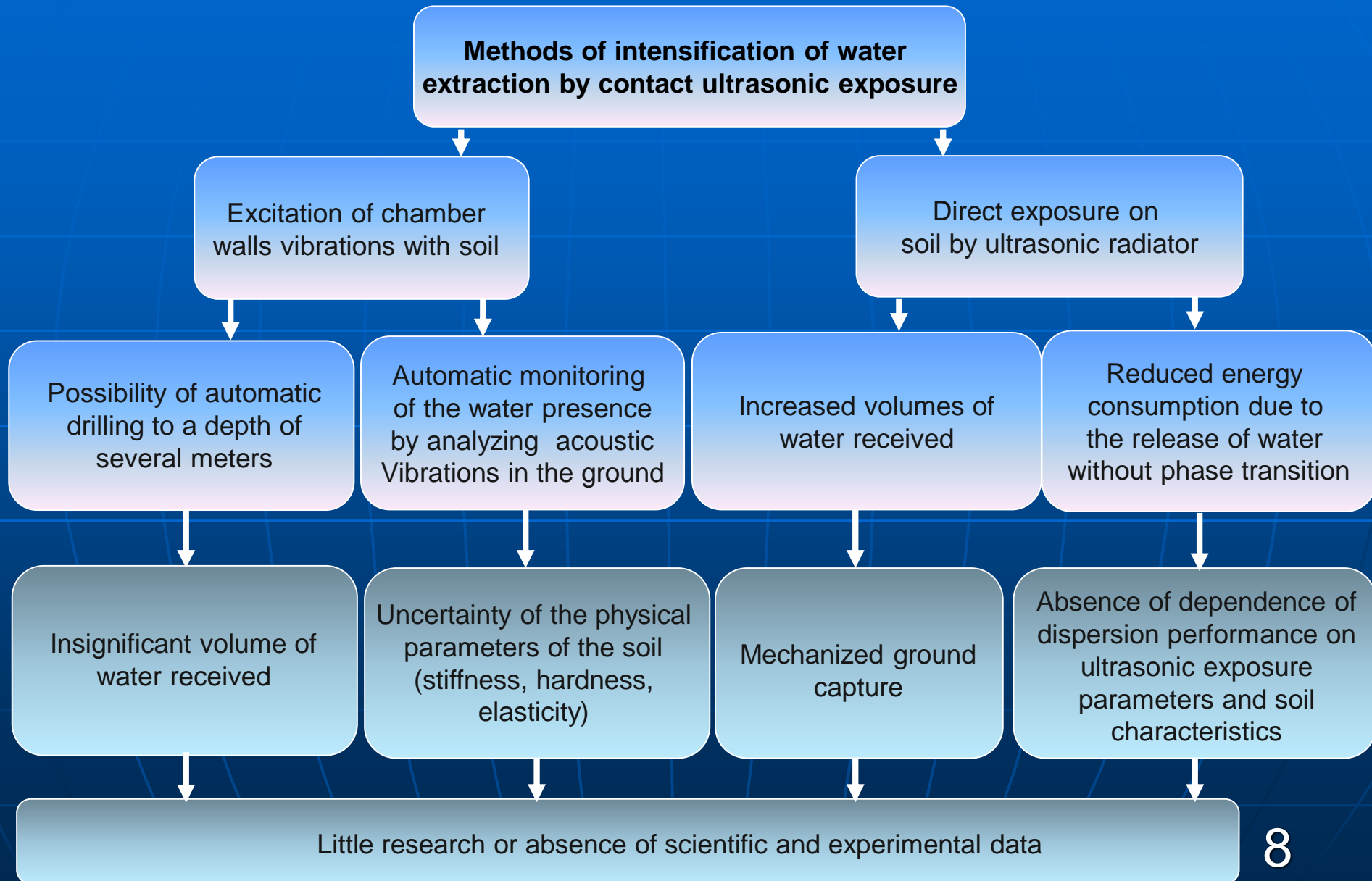

# Process of ultrasonic extraction of water

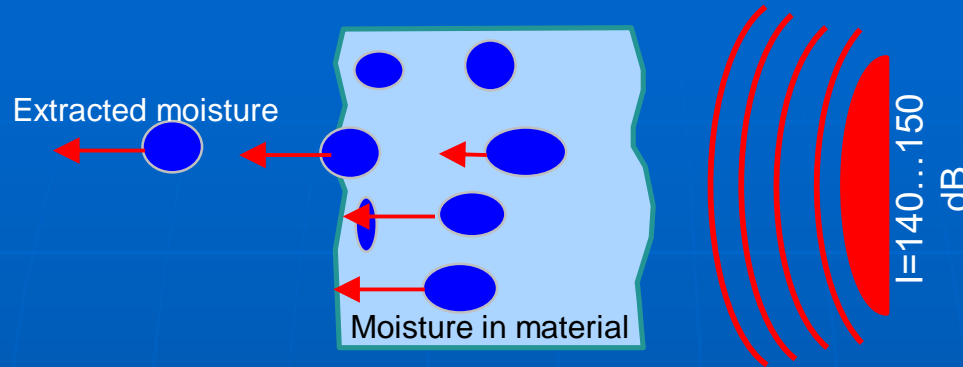

## Advantages of ultrasonic extraction

1. Increasing of efficiency.
2. Decreasing of power consumption.
3. Extraction at low temperature.

Ultrasonic vibrations provides maximum effective exposure on the soil for the water extraction process.

Ultrasonic vibrations can extract moisture from porous soil at low temperatures

# Ultrasonic extraction of moisture from materials (drying)

Drying is the process of removing moisture from a material to give it new properties, long-term storage, processing, isolation of useful properties in liquid form (extraction without extragent)

Disadvantages of convective drying:

1. High energy intensity and duration.
2. Restriction on the minimum size of drying machines.
3. The impossibility of drying materials destroyed when the temperature rises.
4. The possibility of drying out and spoilage.

Comparative characteristics of drying methods

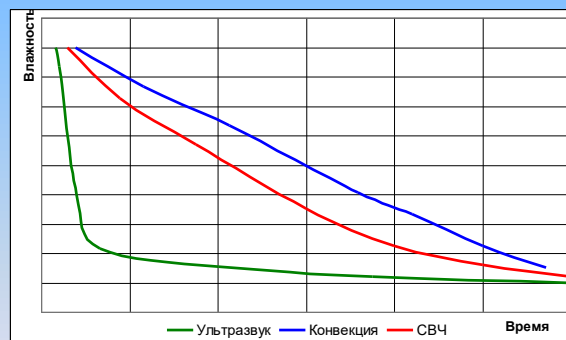

The main advantages of ultrasonic drying:

1. Reduced energy consumption.
2. The possibility of providing high-quality and efficient drying at lower air temperatures.

# Operating factors of acoustic (ultrasonic) moisture extraction

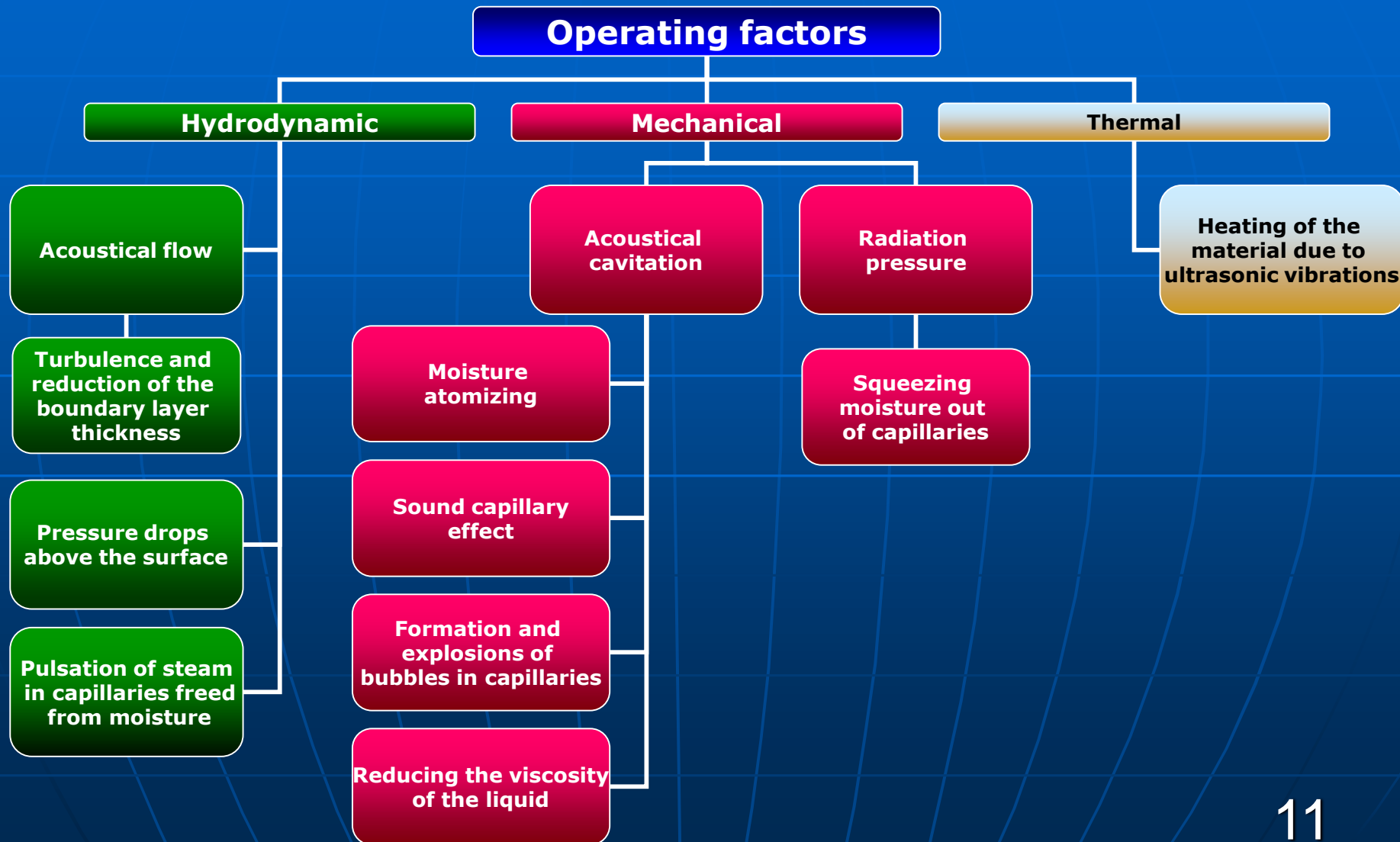

# Pressure drops above the surface

- Changing areas of high and low pressure form over a soil surface at distribution of ultrasonic vibrations.
- The rate of moisture extraction process practically does not slow down in the high-pressure area, according to Boucher's hypothesis. Simultaneously, an additional effect of vacuum extraction occurs in the low-pressure area.

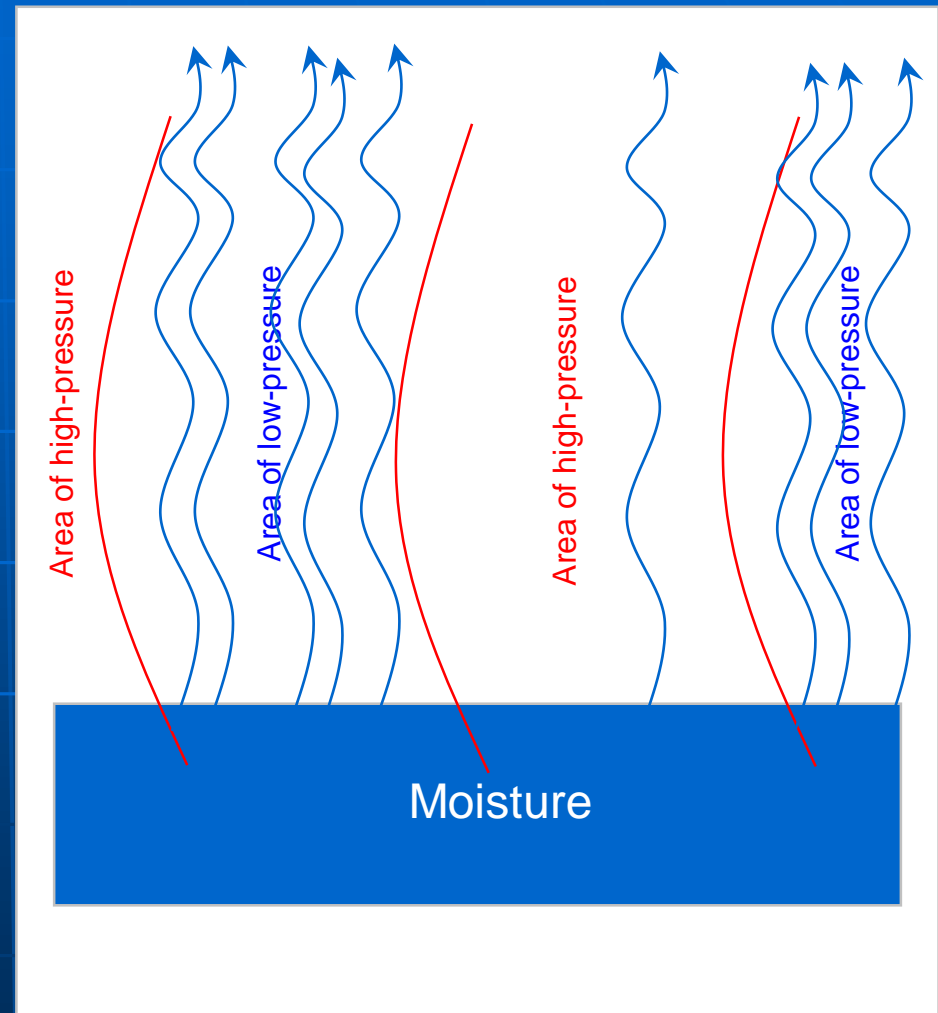

# Acoustic flows in a confined space

- Flows in a liquid and gas medium during the propagation of a high-intensity acoustic wave are caused by viscous friction.
- Acoustic flows are laminar and directed along the propagation vector of the sound wave in an infinite medium.
- Acoustic flows are closed, and vortices form near the boundary layer in the conditions of a standing acoustic wave.
- The speed of acoustic flows depends quadratically on the sound pressure and in the range of 140-150 dB is 6-10 m/s

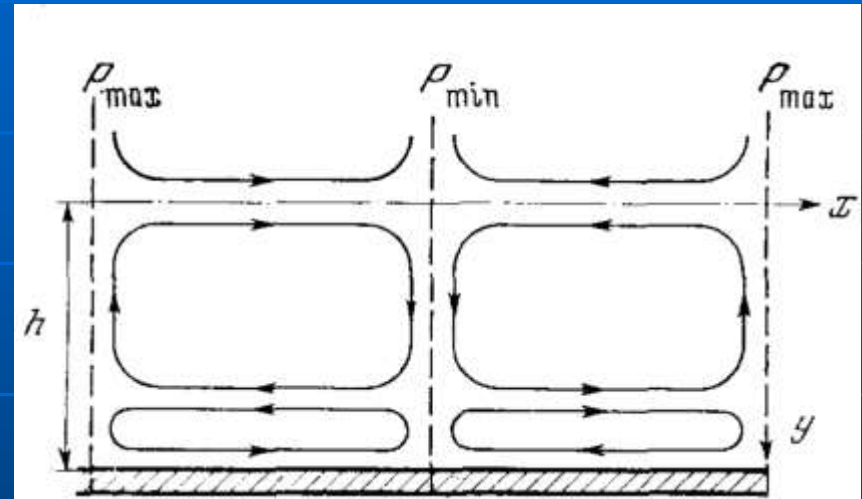

Scheme of formation of acoustic flows in the boundary layer

The main intensifying force of moisture removal is acoustic flows that accelerate the process of moisture evaporation and its removal from the boundary layer at a sound pressure level of 140-150 dB.

# Reducing the thickness of the boundary layer

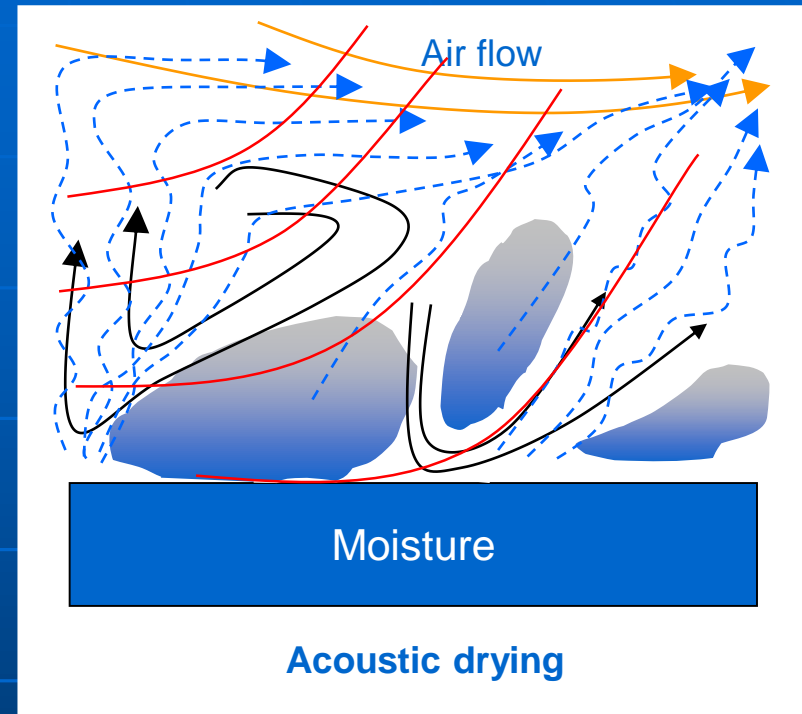
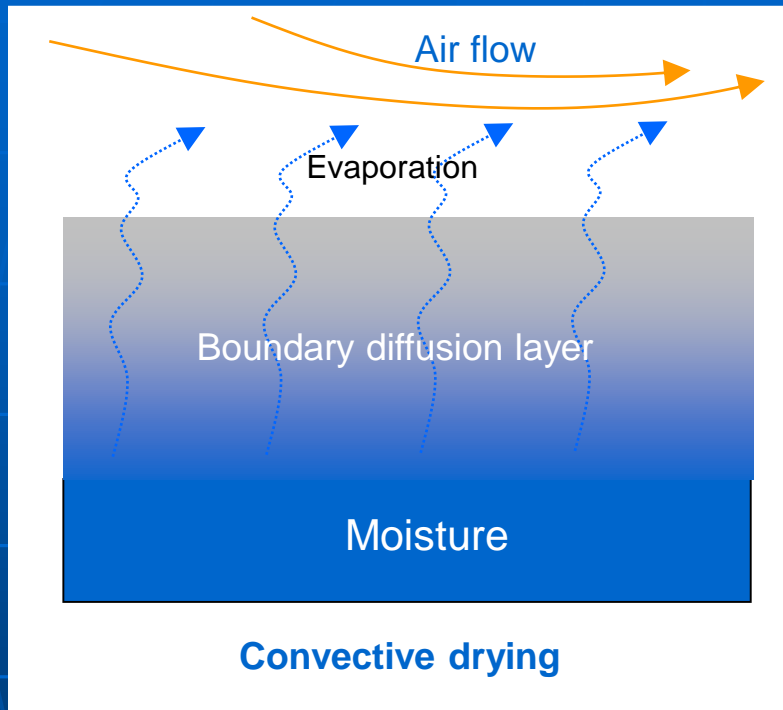

- A boundary layer near the surface of the wet material prevents mass transfer. Reducing the thickness of the boundary layer increases in the rate of moisture removal.
- The thickness of the boundary layer is determined by diffusion and hydrodynamic processes.
- The air flow in the near-surface layer is laminar and the thickness of the boundary layer is determined mainly by diffusion processes at convective removal of moisture.
- The thickness of the boundary layer decreases sharply due to the occurrence of turbulent near-surface currents and micro-flows in an intense acoustic field.

# Radiation pressure

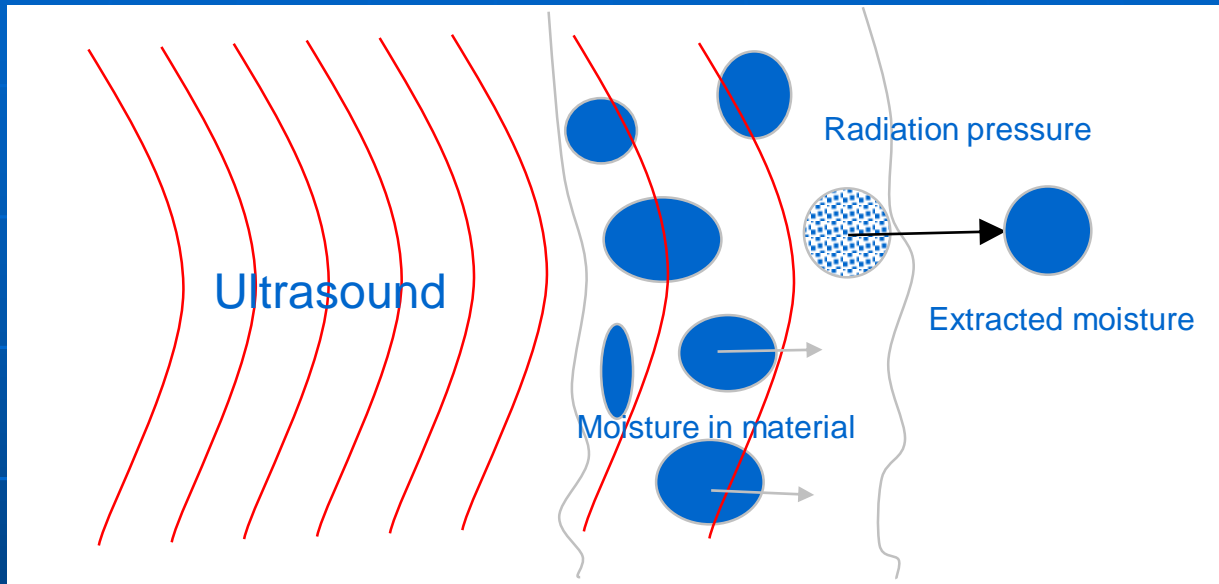

- Radiation pressure (incident wave pressure, sound pressure) is a constant component of the pressure acting on a body placed in an ultrasonic field. Radiation pressure occurs due to the transmission of a part of the pulse of the incident wave to the body during its absorption or reflection. The radiation pressure arising in ultrasonic fields with an intensity of over 135 dB is capable of squeezing moisture out of a capillary-porous material

# Cavitation

- The phenomenon of cavitation occurs at propagation of high-intensity ultrasonic vibrations in a liquid.
- The cavitation is the main acting force that intensifies many physic-chemical processes at exposed to substances with high-intensity ultrasound (including the process of moisture extraction).
- Cavitation is associated with a violation of the liquid continuity in the rarefaction phase, the formation of vapor-gas bubbles in the rupture area and their slamming in the subsequent compression phase.
- An arise cumulative jet cause a shockwave in the liquid at the moment of slamming due to the inevitable asymmetry of the bubble.

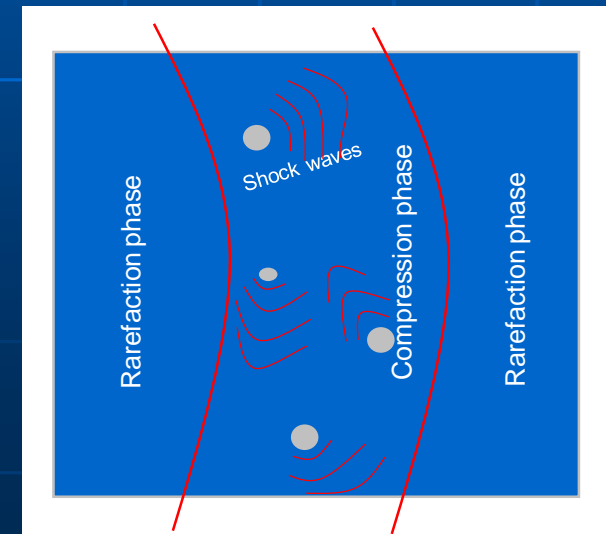
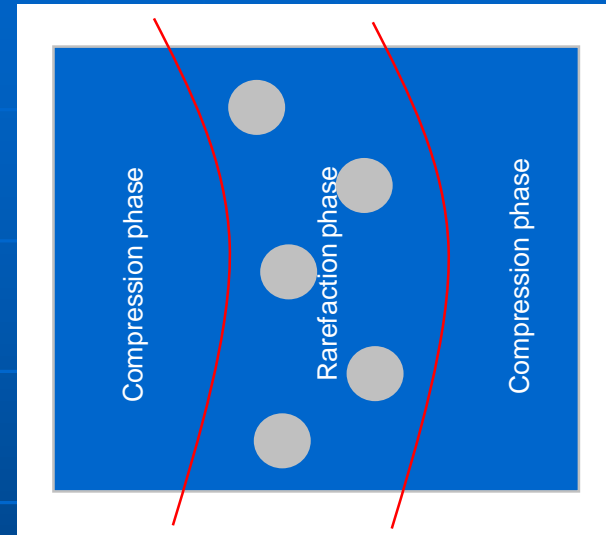

# Cavitation moisture removal

- The explosion of cavitation bubbles near the free surface causes gravitational-capillary waves. The pointed crests of gravitational-capillary waves break up into droplets.
- The separated droplets form an aerosol in an equilibrium state, because other influences are in absence.
- The aerosol is effectively removed in the presence of acoustic currents, radiation pressure or air flow over the free surface of the liquid.
- Cavitation atomizing allows the removal of moisture without phase transition. This reduces the energy intensity of the drying process.
- **Cavitation atomizing occurs only in the presence of a liquid phase and sufficient intensity of ultrasonic vibrations.**

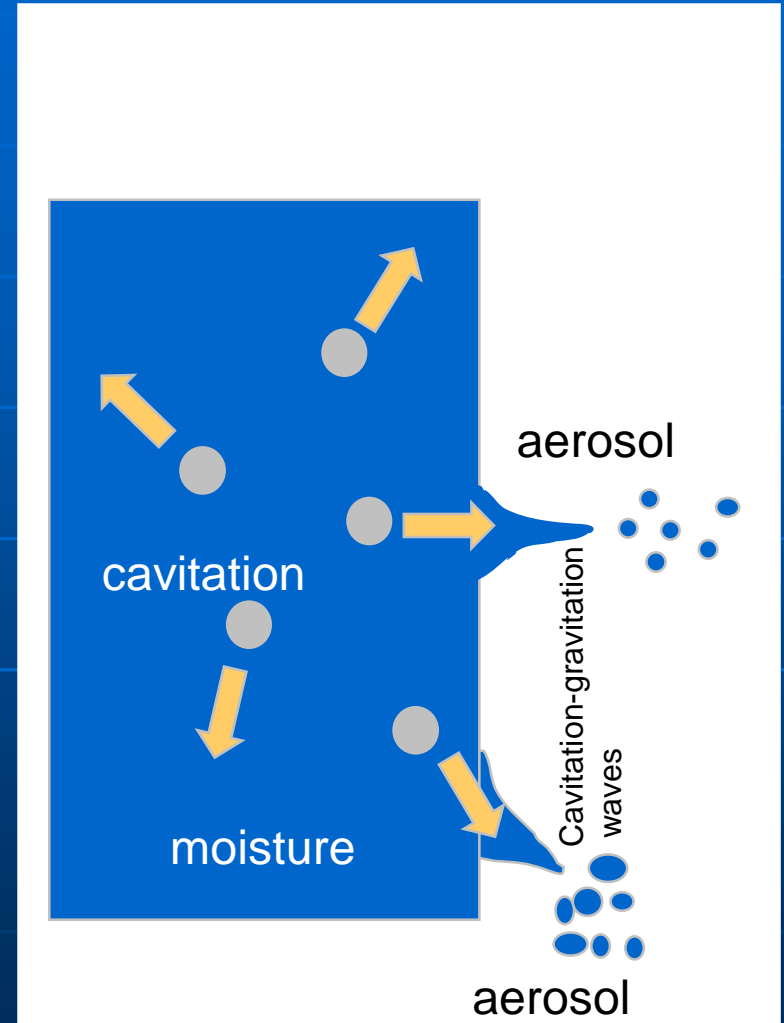

# Sound capillary effect

- The shockwave will be directed into the capillary when a cavitation bubble grows and closes at the entrance to the capillary.
- The excess pressure in the capillary pushes the column of liquid out. This phenomenon is called the sound capillary effect.
- The sound capillary effect accelerates transfer of moisture from the deep layers to the surface, thus contributing to an increase in the rate of moisture removal.

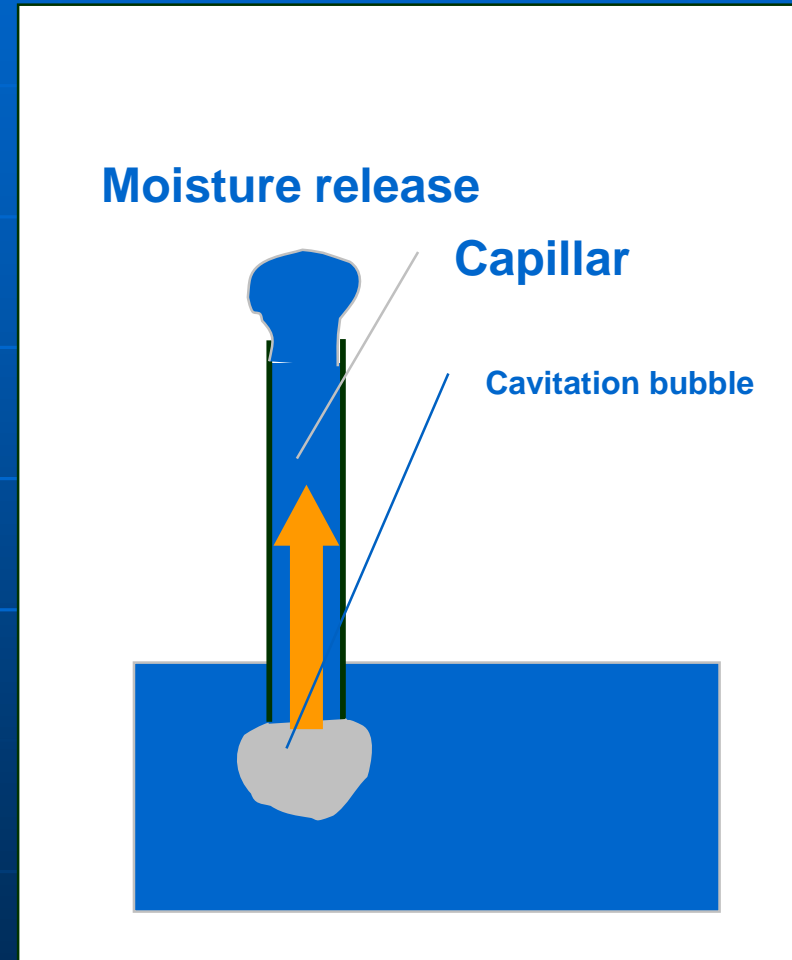

# Pulsations and explosions of vapor-gas bubbles in capillaries, decrease in liquid viscosity

- Some vapor-gas bubbles do not have time to close in the compression phase to increase intensity of cavitation in the liquid. Such bubbles increase in size again in the next phase of rarefaction. This process repeats for a long time. Such bubbles are called resonant.
- Pulsations of resonant bubbles in the capillaries cause vibrations of the walls. This accelerates the process of moisture transfer.
- Bursts of bubbles in capillaries also lead to accelerating the process of moisture transfer.
- Cavitation bubbles in the liquid cause its "loosening" and, as a consequence, a decrease in viscosity. This is also a factor accelerating mass transfer.

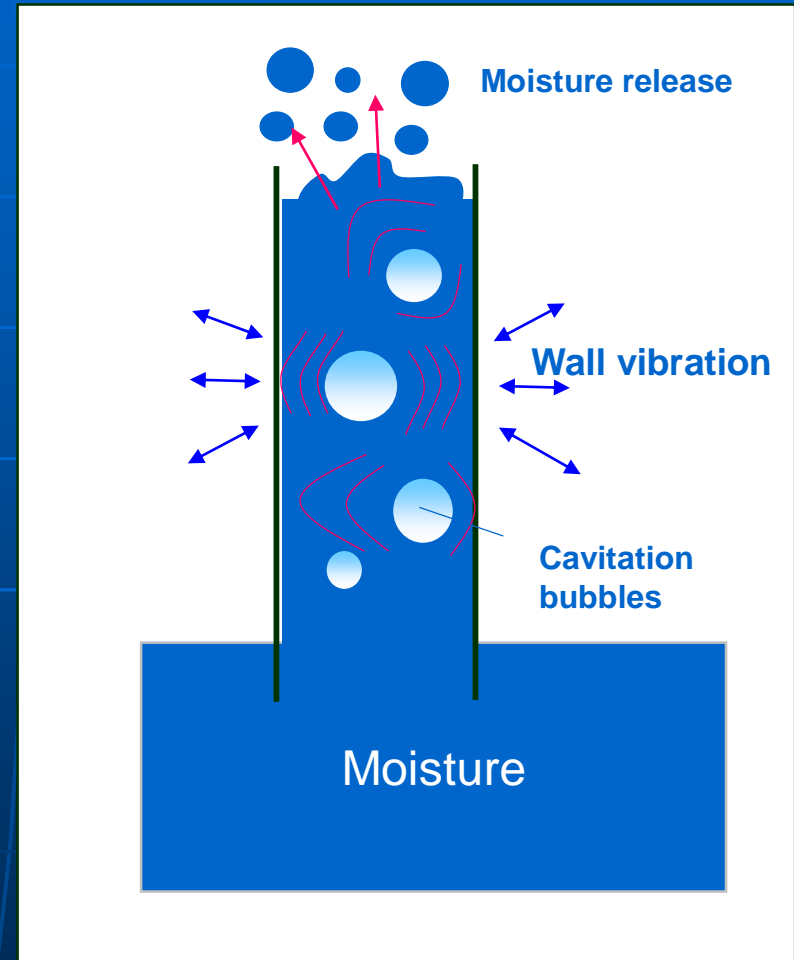

# Thermal effect

- The absorption of ultrasonic vibrations by the material heats up it.
- This process of material heating occurs almost uniformly throughout the depth. This contributes to the accelerated transfer of moisture from the deep layers.
- The thermal effect of ultrasound is effective only at high intensities (over 165 dB) and to a greater extent in bulk materials.

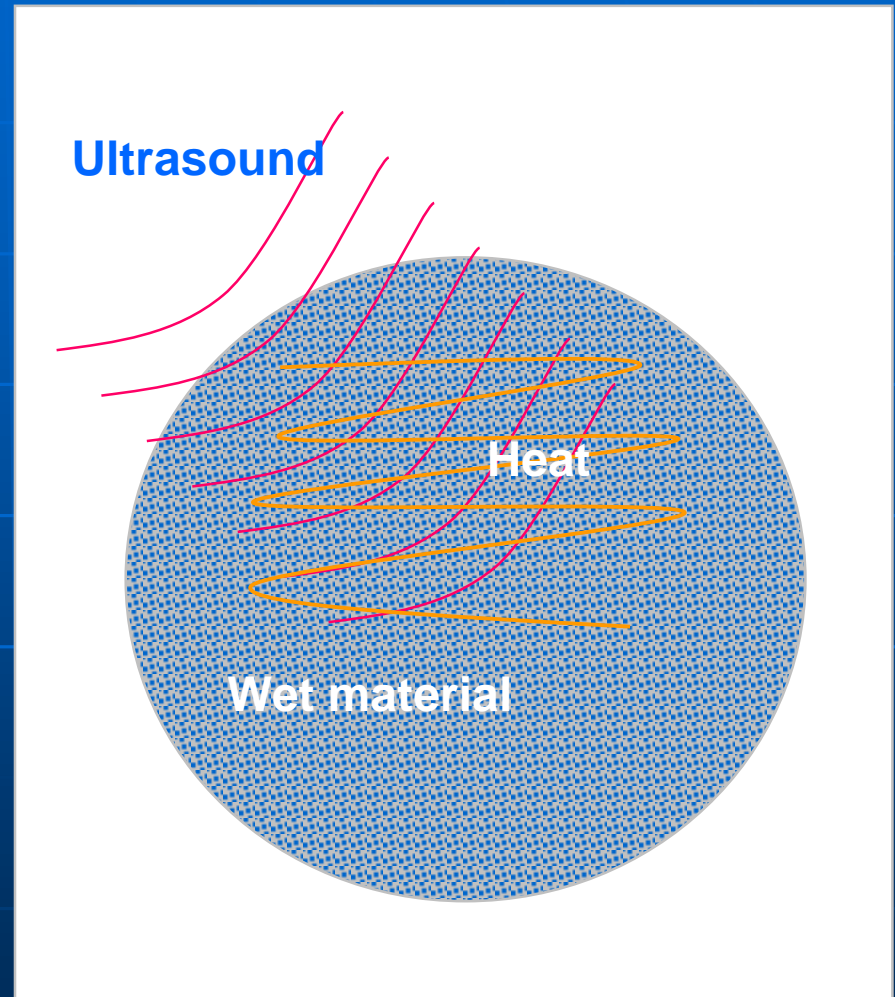

# Influence of ultrasonic vibrations on wet material



# Structure and properties of regolith

A non-layered, loose, multi-grained debris-dust layer with a thickness of several tens of meters. It consists of fragments of igneous rocks, minerals, glass, meteorites and breccias of shock-explosive origin, cemented with glass.

It refers to dusty sands according to the granulometric composition. The bulk of the particles has a size of 0.03—1 mm.

Lykov A.V. considers a layer of sand 10 cm thick as a porous body if the grain radius is greater than 0.025 mm. Therefore, it is possible to disperse moisture from pores and capillaries due to the formation and collapse of cavitation bubbles.



Photo of the regolith delivered by Luna-16

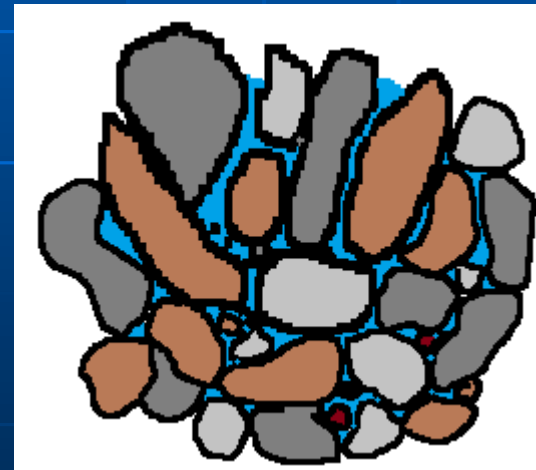

Illustration of a regolith model with the presence of ice

# Thermal effect

A significant thermal effect is created as a result of mechanical friction between the regolith and the radiator surface.

Ultrasonic waves penetrate relatively well inside in materials with macrocapillaries ( $0.2 \mu\text{m} < \text{diameter} < 20 \mu\text{m}$ ) and pores and has absorbed with internal heating. Noticeable heating is observed in bulk materials and relatively weak – in solid porous plates.

The results of experimental studies on ultrasonic drilling of the lunar soil simulator (compacted sand, sandstone crumbs, etc.) at a temperature of  $-100\text{ }^{\circ}\text{C}$  showed an increase in soil temperature only for the first 3 minutes of exposure to  $25\text{ }^{\circ}\text{C}$  or more at a distance of 10 mm from the radiator.

This allows us to make an assumption about the possibility of melting ice at low initial negative temperatures with followed evaporation and dispersion of water.

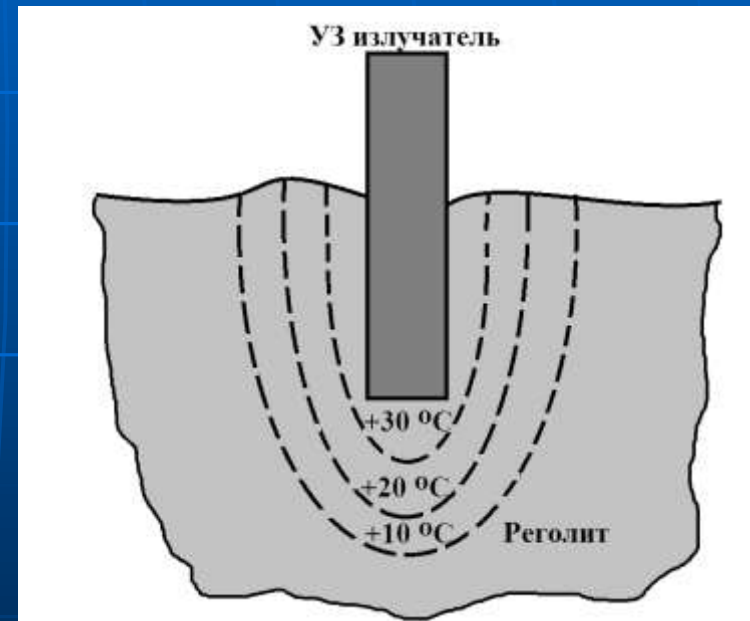

# Ultrasonic exposure on ice

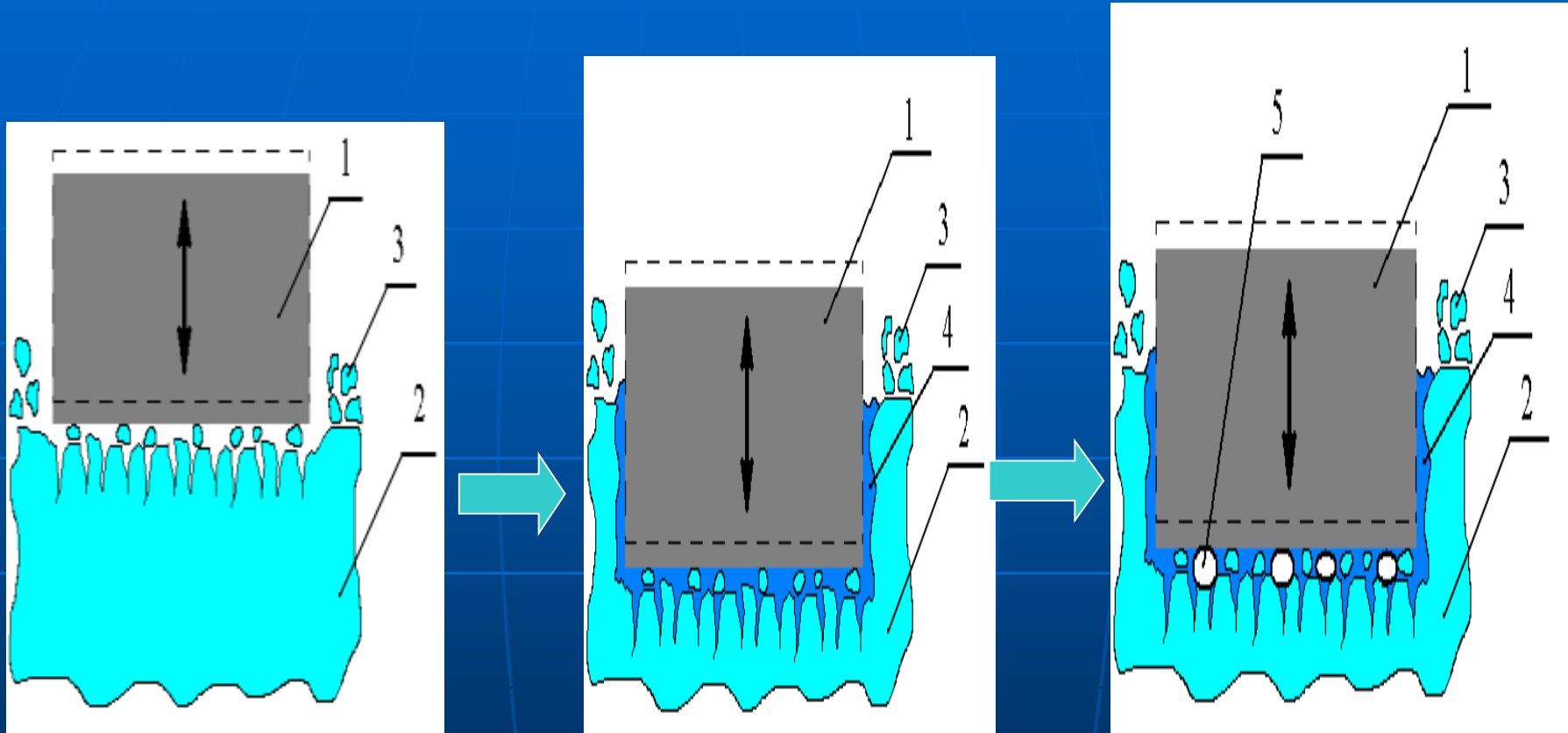

1 – ultrasonic working tool; 2 – ice; 3 – shards of ice; 4 – water;  
5 – cavitation bubbles

# Calculation of the growth of a cylindrical cavitation cavity

It is assumed that the cavitation bubble is transformed into a cylindrical shape due to the presence of a limited volume of ice in the lunar soil. Therefore, the equation of continuity and conservation of momentum in cylindrical coordinates was used to calculate its growth:

$$\frac{\partial u}{\partial r} + \frac{u}{r} + \frac{\partial v}{\partial z} = 0$$

$$\rho \left( \frac{\partial u}{\partial t} + u \frac{\partial u}{\partial r} \right) = - \frac{\partial p}{\partial r}$$

$$\rho \left( \frac{\partial v}{\partial t} + u \frac{\partial v}{\partial r} \right) = - \frac{\partial p}{\partial z}$$

$r$  – the distance from the axis of symmetry of the cylindrical cavitation cavity, m;  $z$  – the coordinate along the axis of symmetry of the cavitation cavity, m;  $u, v$  – the components of the velocity of the liquid surrounding the cavity along the  $r$  axis and along the  $z$  axis, respectively, m/s;  $p$  – the liquid pressure, Pa;  $\rho$  – the density of the liquid, kg/m<sup>3</sup>

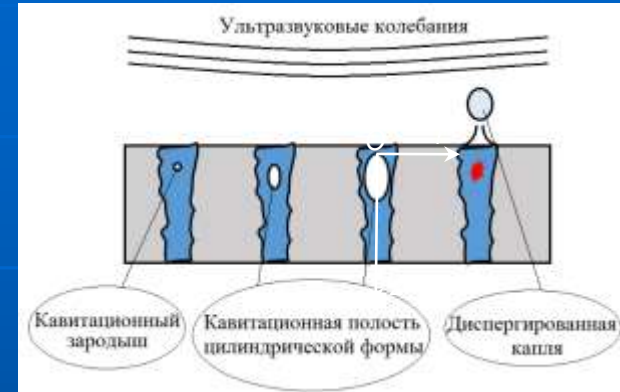

Assume that the liquid flow is potential and using the Laplace equation. The solution for the velocity potential is in the form:

$$\varphi = -\frac{Br^2}{4} + C \ln r + \frac{Bz^2}{2} + Dz + E$$

$B, C, D, E$  – function, depended from time  $t$ , but not depended from coordinates  $r, z$

Substituting into the momentum conservation equations:

$$p = p_0 - \rho \frac{\partial}{\partial t} \left( -\frac{Br^2}{4} + C \ln r + \frac{Bz^2}{2} + Dz + E \right) - \rho \frac{\left( -\frac{Br}{2} + \frac{C}{r} \right)^2 + \left( B^2 z^2 + 2DBz + D^2 \right)}{2}$$

We obtain an equation for the dependence of the cylindrical cavitation cavity radius on time:

$$R^2 = \left( R_{cy0} + R_{cylA} \sin(\omega t) \right)^2 + \frac{\left( \left( R_{cy0} + R_{cylA} \sin(\omega t_{start}) \right)^2 - R_0^2 \right)^2}{2\omega \left( R_{cy0} + R_{cylA} \sin(\omega t_{start}) \right) R_{cylA} \cos(\omega t_{start})} - \frac{\left( R_{cy0} + R_{cylA} \sin(\omega t_{start}) \right)^2 - R_0^2}{2\omega \left( R_{cy0} + R_{cylA} \sin(\omega t_{start}) \right) R_{cylA} \cos(\omega t_{start})} - t_{start}$$

$t_{start}$  – initial time of ultrasonic exposure, s;  $R_{cy0}$  – initial radius of capillary, m;  $R_{cylA}$  – amplitude of vibrations of the capillary radius, m

The expansion of the cavitation bubble to a size sufficient for collapse requires about  $10^4$  vibration periods (no more than 0.5 s) for an elongated pore diameter of 20  $\mu$ m

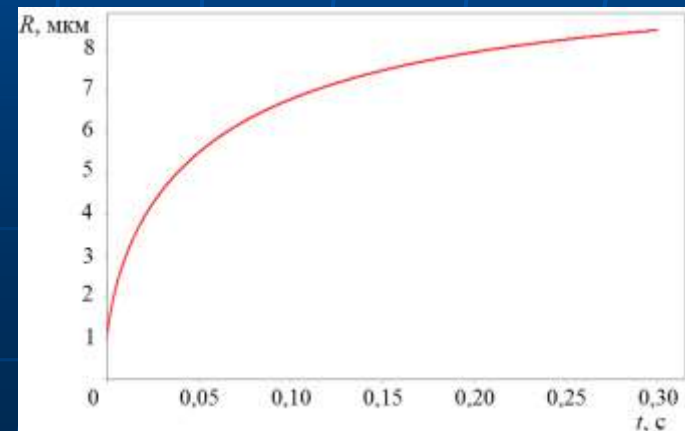

# Dispersed water at different soil moisture contents

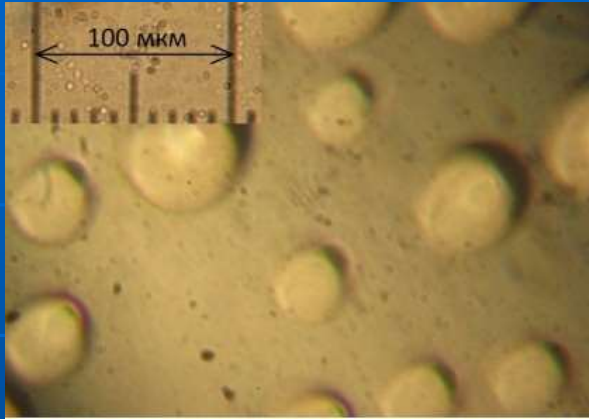

3.5 kg/kg

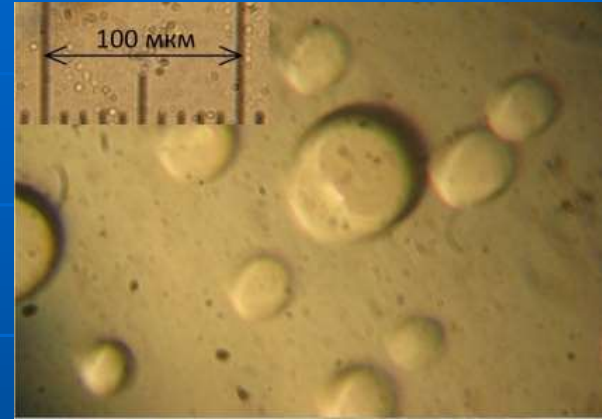

2.8 kg/kg

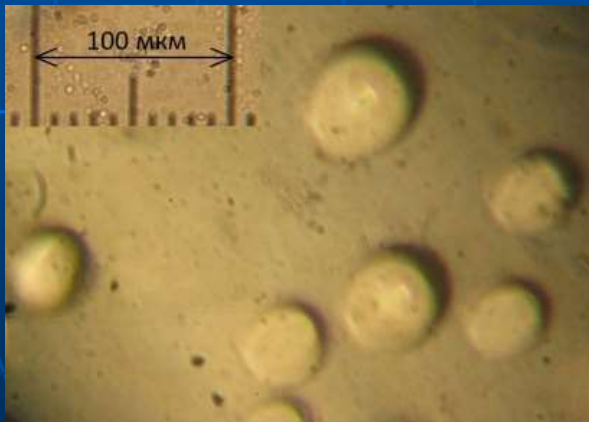

2.2 kg/kg



1.5 kg/kg

# Average drying rates depending on the sound pressure level

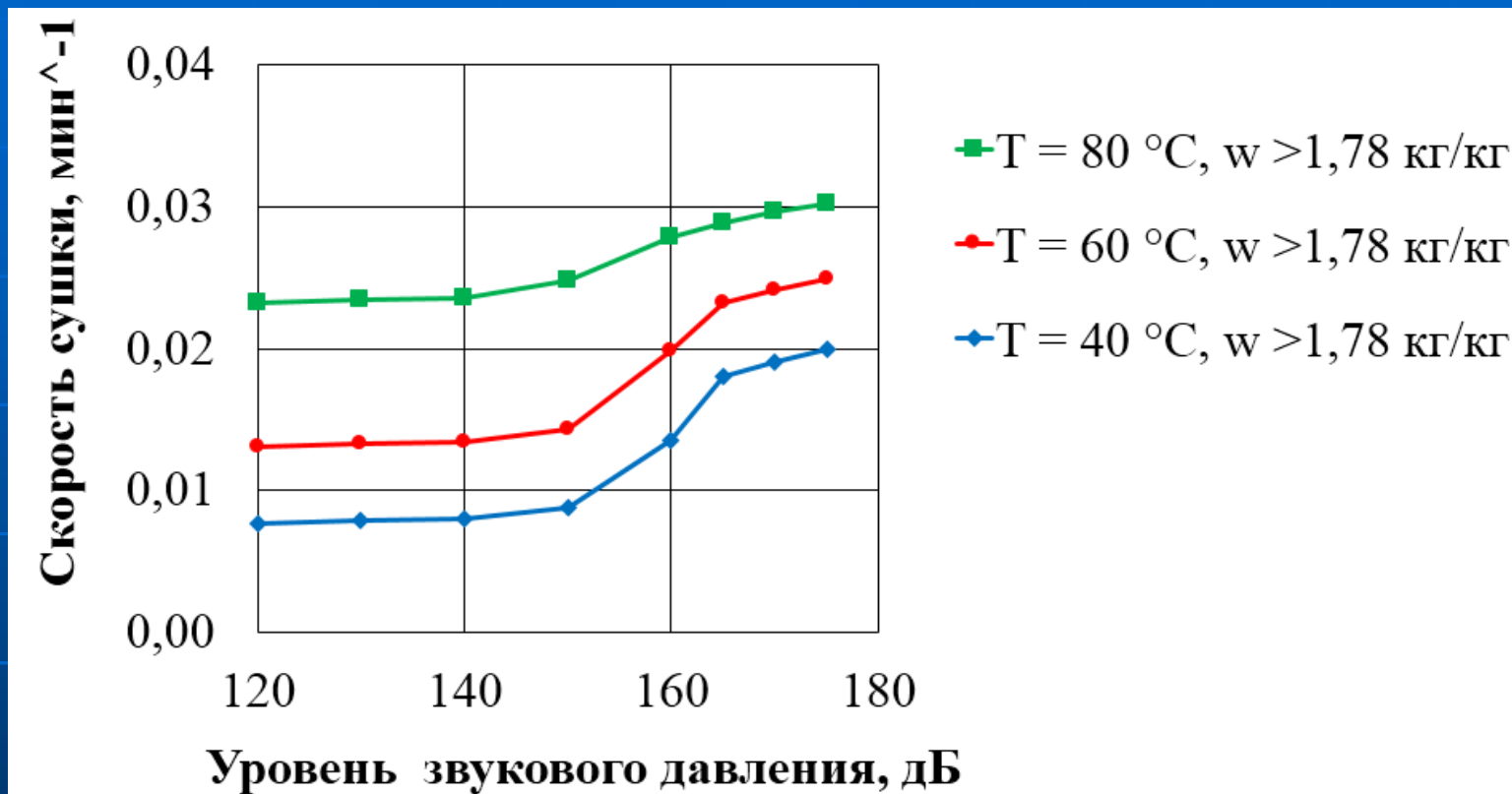

Dispersion of moisture in the capillary-porous material occurs at a sufficient amount of moisture and a sound pressure level of more than 150 dB. The relative efficiency of dispersion is the higher, the lower the temperature.

# Water extraction technologies

## Ultrasonic technology of excitation of tubular chamber walls

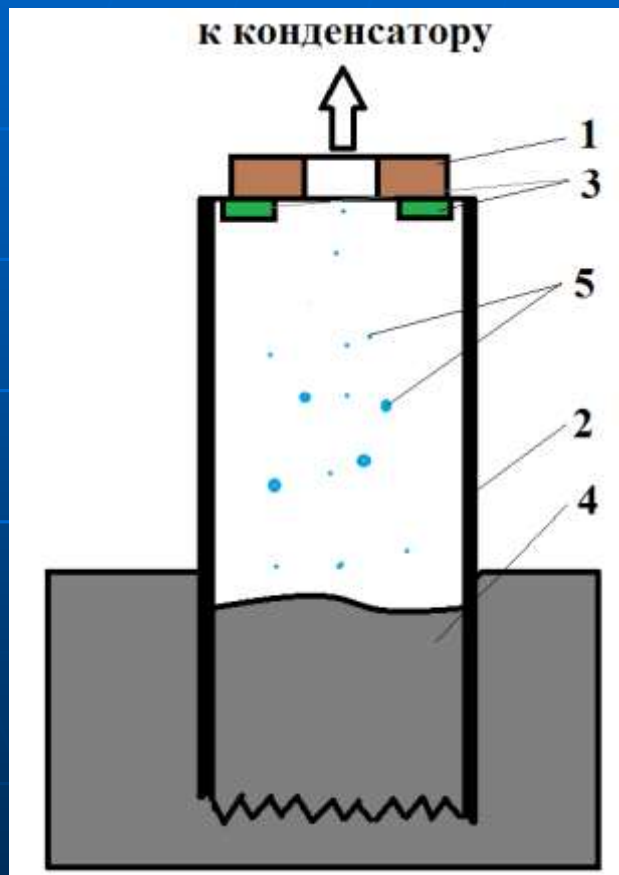

1. Piezoceramic
2. Walls of the tubular ultrasonic radiator
3. Additional water sensors (if necessary)
4. Soil (regolith)
5. Water droplets and steam

It is proposed to use at depths of about one meter, where the temperature of the regolith is constant (about  $-35^{\circ}\text{C}$ ). It can be used to detect the presence of water in the regolith by processing acoustic vibrations and information from additional sensors and deciding on the possibility of further water extraction.

Extraction of small volume

# Technology of contact ultrasonic exposure by the radiator

Can be used to extract water from regolith containing water ice. Sublimation, evaporation and dispersion of water with precipitation and condensation on the condenser occurs at directly exposing to the soil. Large drops flow into a container of water and ice.

Advantages:

1. Possibility of water outlets without phase transition;
2. Cost reduction

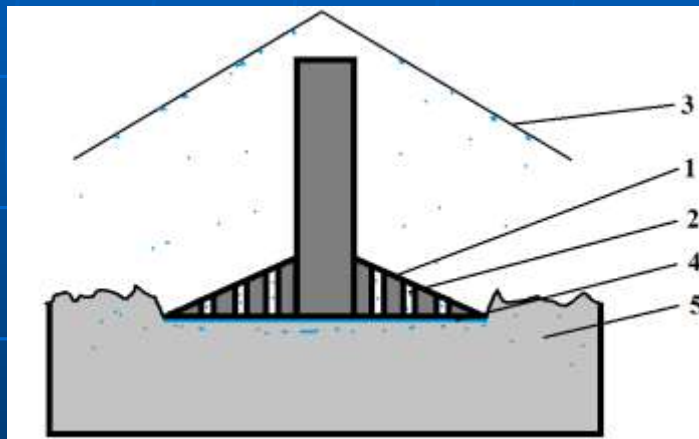

Ultrasonic exposure from above: 1 – ultrasonic radiator-drill; 2 – channels for steam output; 3 – condenser ; 4 – water; 5 – regolith with ice

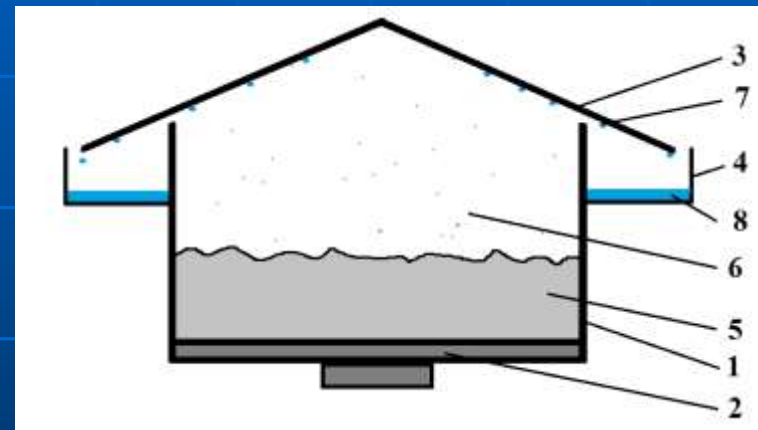

Ultrasonic exposure from below: 1 – dryer case; 2 – ultrasonic radiator; 3 – condenser cover; 4 – water and ice container; 5 – soil (regolith); 6 – water droplets and steam; 7 – condensed water droplets; 8 – water and ice

Propagation and absorption of ultrasonic vibrations in the soil up to several tens centimeters

Large area of ultrasonic contact exposure

# Technology of contactless ultrasound exposure

Assumes the presence of a gases extracted from regolith or introduced artificially

Ultrasonic water miner

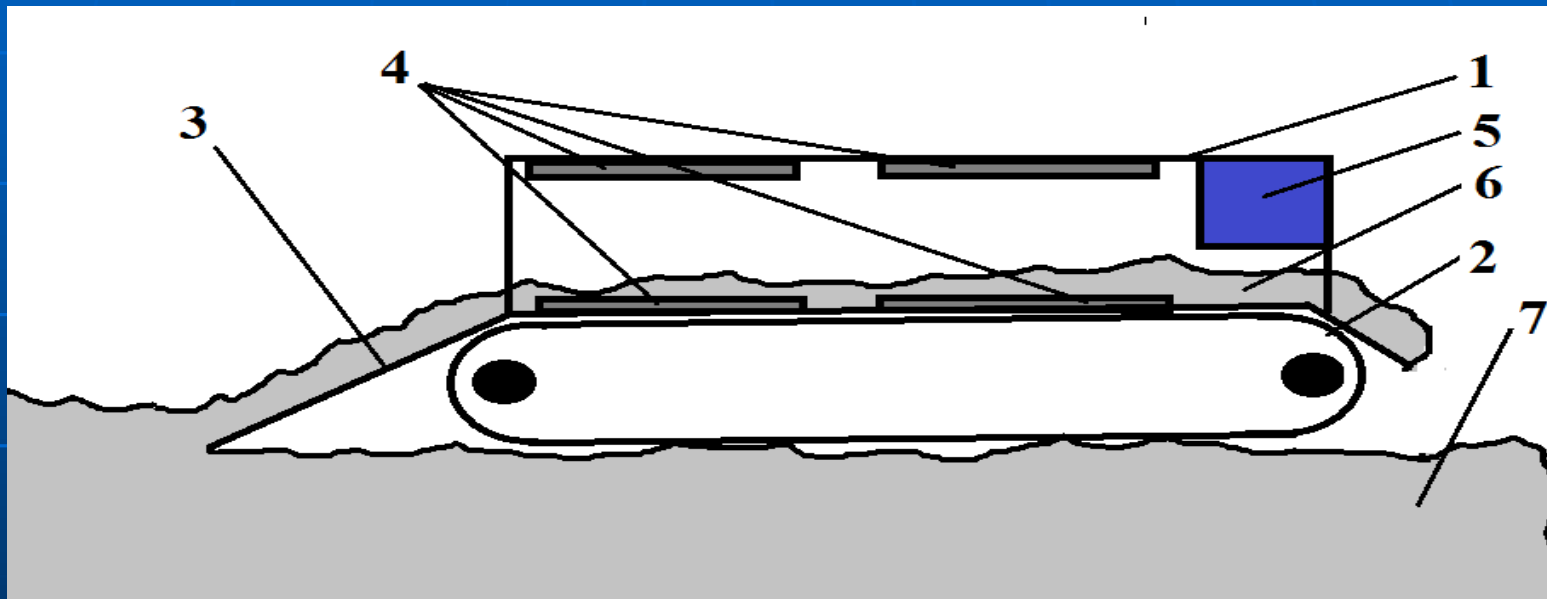

- 1 – the body of the water miner, 2 - tracks,  
3 – shovel, 4 – ultrasonic radiators,  
5 – condenser, 6 – dehydrated regolith;  
7 - regolith

# The principle of the ultrasonic drum device of horizontal type

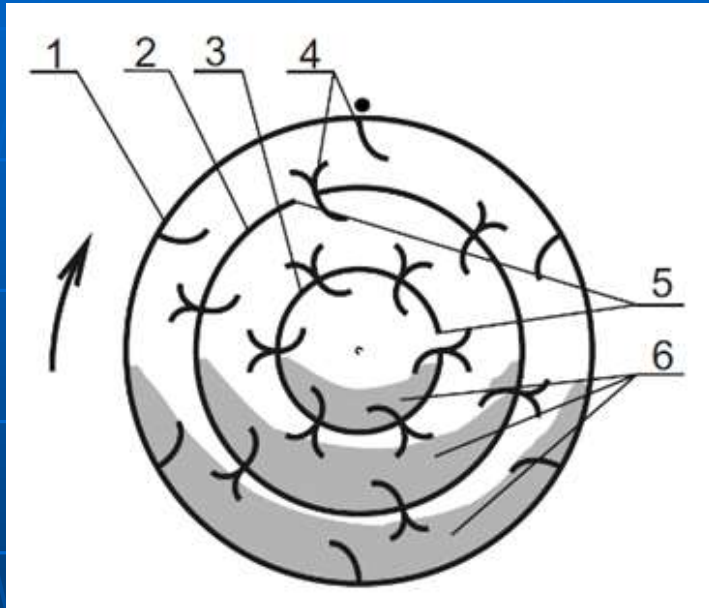

initial position

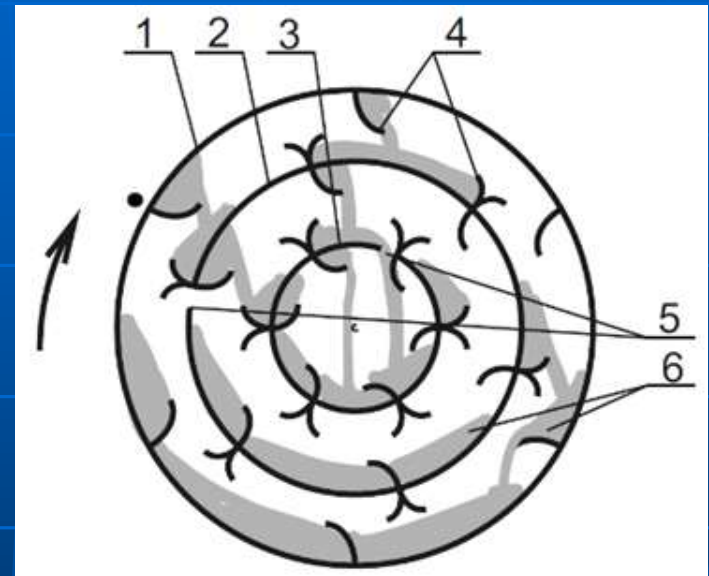

after rotation on 300 degree

1 – drum, 2, 3 – cylindrical surfaces, 4 – blades,  
5 – longitudinal holes, 6 – wet material

# The ultrasonic device of vertical type

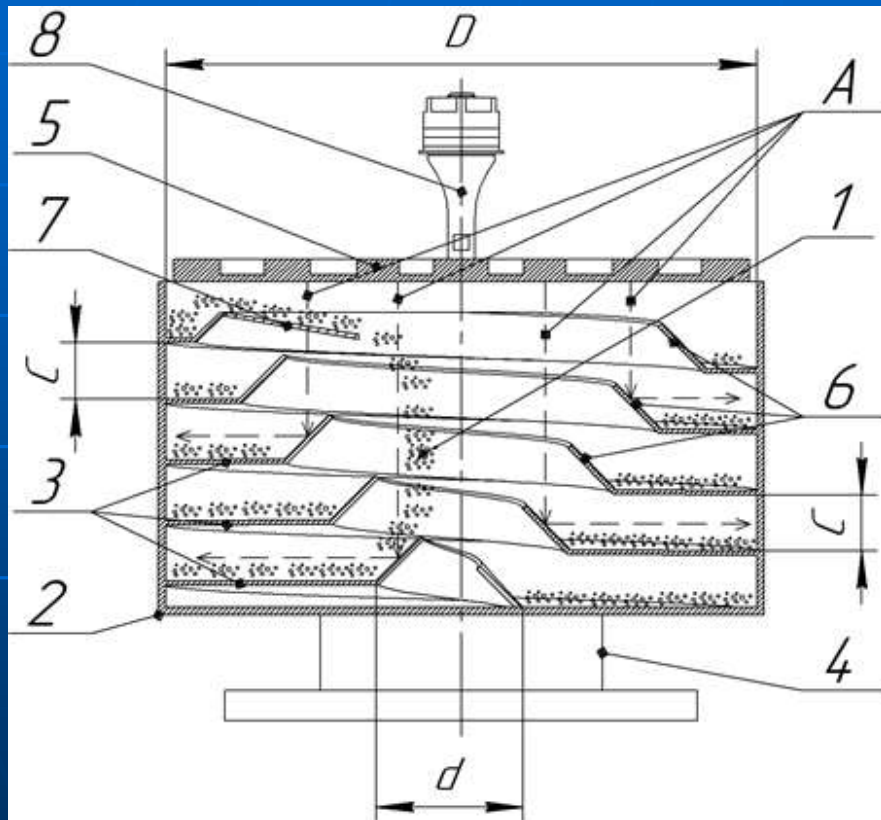

1 – wet material; 2 – cylindrical drum;  
3 – spiral tray; 4 – vibration driver;  
5 – ultrasonic radiator; 6 – ultrasonic  
vibration reflector; 7 – the upper turn of  
the spiral tray; 8 – piezoelectric  
transducer; A – the maximum and  
minimum distances from the radiator to  
two diametrically located sections of  
the spiral tray; D – the diameter of the  
drum; d – the inner diameter of the  
coils of the spiral tray; C – the distance  
between the coils of the spiral tray

# The drum device

- Drum ultrasonic devices are used for the extraction of moisture from bulk materials.
- The operation mode of the drum devices is periodic.
- The wet material is placed in the drum, where it is exposed by ultrasound (including together with thermal).
- The rotation of the drum contributes to the uniformity of the exposure of vibrations on the entire volume of the material and the extraction of moisture.
- Moisture from the drum device is removed by an exhaust fan.
- Ultrasonic radiation of in-drum devices is created by contact and non-contact radiators.

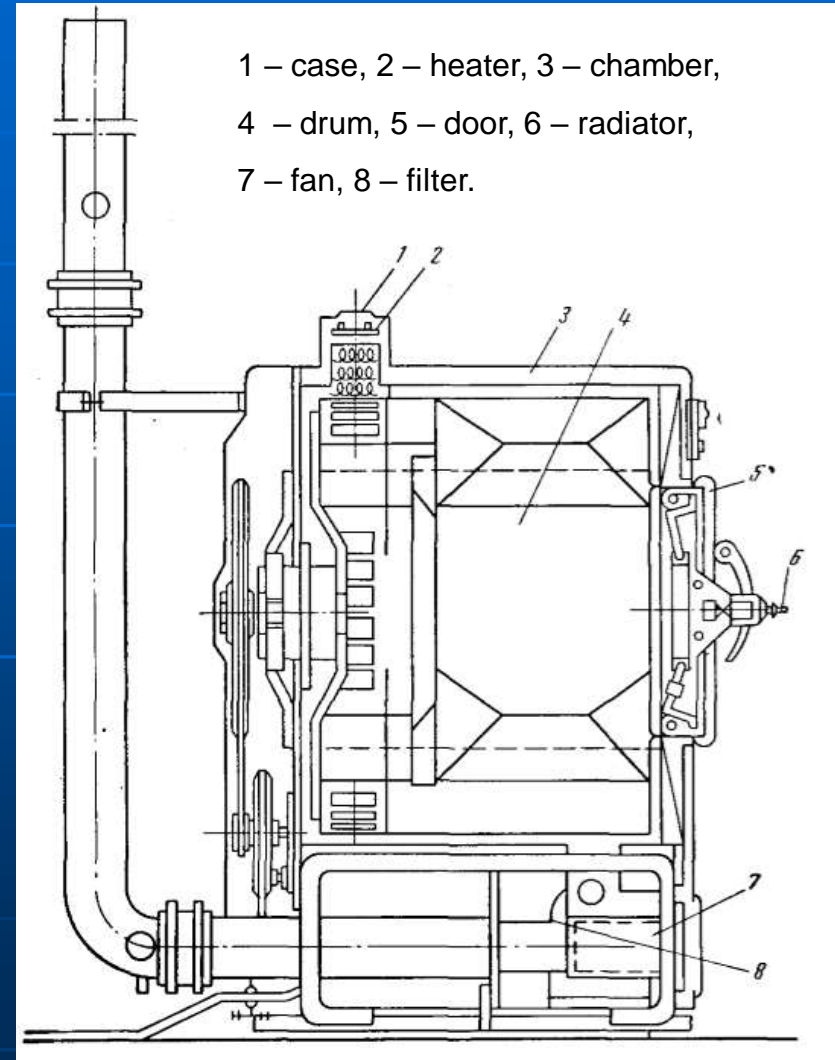

# Construction of a tunnel moisture extraction device

- Unlike drum devices, the tunnel devices are continuous-acting devices.
- The wet material moves through a tunnel by a conveyor, inside which intense acoustic radiation is created.
- Tunnel dryers are used to remove moisture from bulk materials under contact and non-contact exposure

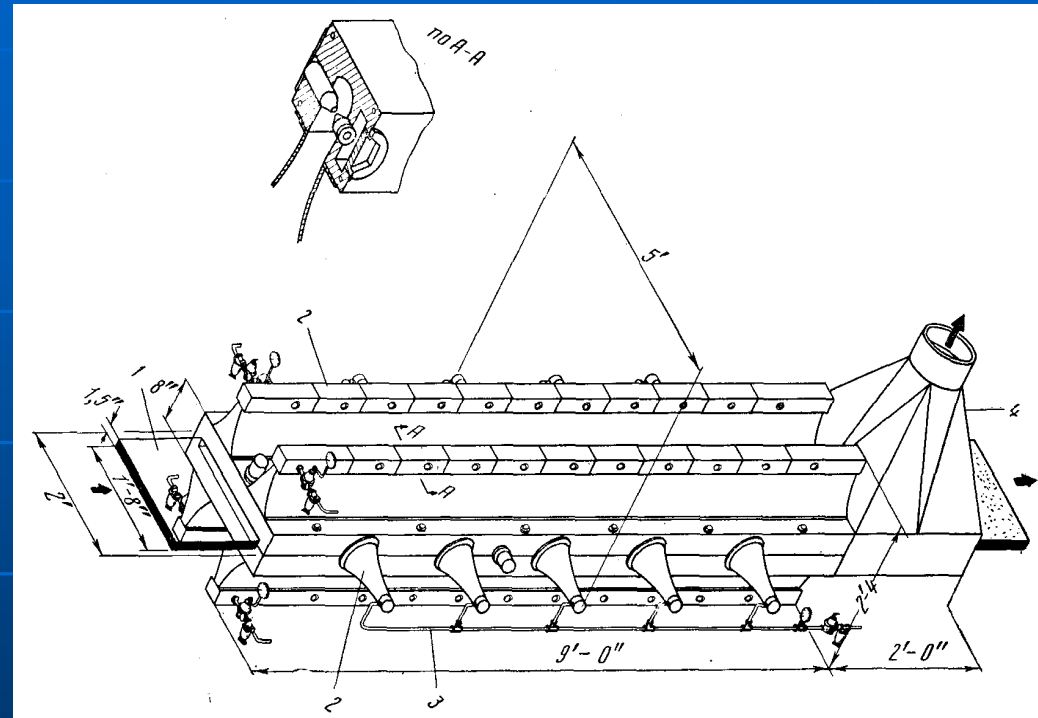

1 – dried material, 2 – radiators, 3 – air supply system, 4 – humid air strangulation system