

Studies of Transformation of Longitudinal Ultrasonic Vibrations into Radial Ones

Viktor A. Nesterov, *Student Member, IEEE*, Vladimir N. Khmelev, *Senior Member, IEEE*,
Aleksy N. Slivin, Andrew V. Lehr, *Student Member, IEEE*

Biysk Technological Institute (branch) Altai State Technical University after I.I. Polzunov, Biysk,
Russia

Abstract – In the article the process of transformation of longitudinal vibrations into radial ones was investigated, different constructions of the transducers (symmetric, partially symmetric and asymmetric) intended for continuous strip sealing of thermoplastic materials were analyzed. Computing made by the mathematical modelling was presented and the construction of the welding tool designed for continuous strip sealing of thermoplastic materials was developed.

Index terms – ultrasound, transducer, welding, polymer

I. INTRODUCTION

At present high-intensity ultrasonic vibrations are widely used in industry. The application of the ultrasonic vibrations for welding of thermoplastic materials is the most perspective. Ultrasonic welding is used for the production of film, list and body articles made of polymer thermoplastic materials. Film articles from polymer materials are applied for the storage of food and industrial products. In many cases during the packaging of products joined surfaces can be polluted by the products to be packed. To join such surfaces only ultrasonic welding can be used.

The problem of formation of the continuous weld is urgent and its solution is the aim of the developers of the ultrasonic equipment. Used nowadays systems of ultrasonic welding with the knife-typed radiators does not allow to perform the seams longer than 350 mm in one cycle of welding because of power and strengthening restrictions, and the systems with sliding tools in the form of flat surfaces (ski) moving along welded materials are not able to provide stable quality of the seam because of fluctuations of the vibration amplitude, hold-down pressure, etc.

The absence of the equipment providing the formation of continuous (“infinite”) strip sealing restricts functional capabilities of the ultrasonic welding.

As the main elements of the ultrasonic equipment providing the possibility of formation of continuous welding seam and its quality are vibrating system and working welding tool, there is a necessity to develop special systems, which can move on the surface of welded materials and provide the formation of seam with the specified quality along its length.

Further the results of mathematical modelling directed to the creation of specialized ultrasonic welding tool intended for continuous strip sealing of the thermoplastic materials are given.

II. PROBLEM STATEMENT

The most perspective way of obtaining of continuous seam joining is ultrasonic welding with use of the transducer of longitudinal vibrations into radial ones and the supporting roller. The main advantages of such method of welding are high speed

of welding, automatization of the process, possibility to provide qualitative and even along its length weld joint.

The application of the transducer of longitudinal ultrasonic vibrations into radial ones in comparison with the welding tool of of sliding type helps to avoid the bite of the material between the radiating surface and the supporting roller and also the break of welded materials.

The aim of the paper is to study the process of transformation of longitudinal vibrations into radial vibrations in the working tools of different size and shape and to develop welding tool providing even distribution of vibration amplitude of the radiating surface and maximum amplification coefficient. To achieve given aim it is necessary to solve following particular tasks:

- 1) consider different constructions of the working tools for transformation of longitudinal vibrations into radial vibrations and choose the most suitable one;

- 2) carry out modelling of the transducers by the finite element method and correct geometric sizes for obtaining of resonance frequency of 22 ± 1.65 kHz;

- 3) analyze by the finite element method and develop the construction of the welding tool with the resonance frequency of 22 ± 1.65 kHz providing the most coefficient of transformation and even distribution of vibration amplitude along the working surface of the welding tool.

III. THEORY

The distribution of radial vibration amplitude and deformation is so that there is maximum of deformation amplitude in the centre, then the displacement amplitude tends to zero. At the outer side of the vibrating system the displacement amplitude achieves maximum.

The main features of the transducer of longitudinal vibrations into radial ones are resonance frequency and the amplitude of ultrasonic deformations on the outer working surface at the set value of the amplitude of longitudinal vibrations at the input of the transducer. At the input of the transducer ultrasonic vibrations are supplied, they are directed parallel to rotation axis generating the zones of compression and tension. At the reversed compression and tension of the material its cross-section increases and decreases respectively, i.e. the diameter of the working surface of the tool changes. There is a one-to-one correspondence between vibration amplitude at the outer working surface ξ_R and the amplitude of the longitudinal ultrasonic vibrations ξ .

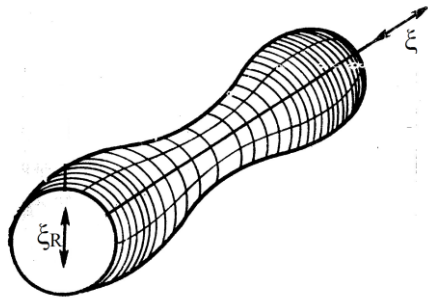

Fig. 1 – Layout view of propagation of longitudinal vibrations in the bar

At present many software products based on the finite element method and intended for solution of single class of tasks are used. One of the most powerful commercial software products is bundled software ANSYS. The specific of the ANSYS is a wide range of the tasks to be solved: strength (both linear and non-linear), heat exchange, hydrodynamics analyses, mixed problems and even acoustic problems [2, 3].

Existing methods of ultrasonic vibration systems calculations let obtain only approximate parameters of single elements [4, 5]. The main time of the design is spent on the modelling of the vibrating system. Moreover the use of empirical formulas with the attraction of experimental results is labor-consuming and requires cumbersome calculations and expenditures. It should be noted, that the data on the calculations can be verified only in the case, when the calculated vibrating system is made and its parameters are measured.

Thus, the development and design of the ultrasonic vibrating system has following stages:

- 1) scoping calculations according to the specified parameters (according to known procedures);
- 2) modelling and analysis of fatigue life;
- 3) correction of the geometry;
- 4) practical realization of calculated construction;
- 5) measurements of the parameters of developed and made ultrasonic vibrating system;
- 6) final calculations with the parameters correction based on the data of the experimental researches.

The development of the ultrasonic vibrating system construction is carried out by CAD, e.g. T-Flex, AutoCAD or COMPAS 3D.

The modelling is made by the program of ANSYS finite element modelling [6].

IV. RESULTS OF MODELLING OF THE WORKING TOOLS

During the work three types of the constructions of the transducers of longitudinal vibrations into radial ones for continuous seam welding of thermoplastic materials were designed:

- «symmetric»,
- «partly symmetric»,
- «asymmetric».

The type of the construction is determined by the relations to the plane, which is perpendicular to the rotation axis and going through the mean line of the radiating surface.

As the main part of the ultrasonic technological equipment used for welding of thermoplastic materials operates at the frequency range of 22 ± 1.65 kHz, it is necessary to develop the construction with the following parameters:

- 1) the resonance frequency is 22 ± 1.65 kHz;

2) the width of the radiating surface is 3–7 mm;

3) the amplitude of radial vibrations is 25–70 micron at the amplitude of longitudinal vibrations $\xi = 50$ micron.

4) the even distribution of the vibration amplitude at the working surface of the welding tool.

Figure 2 shows the results of modelling of the developed symmetric construction with the radial junction. The resonance frequency of the construction is 22 kHz.

The transformation coefficient of longitudinal vibrations into radial ones is $k=0.6$, if the width of the radiating surface is 3 mm. During the formation of continuous seams at the rotation of the working tool the amplitude of radial vibrations will equal to:

$$\xi_R = \xi \times k = 50 \times 0.6 = 30 \text{ micron.} \quad (1)$$

The obtained amplitude is enough for providing of qualitative joining of welded materials.

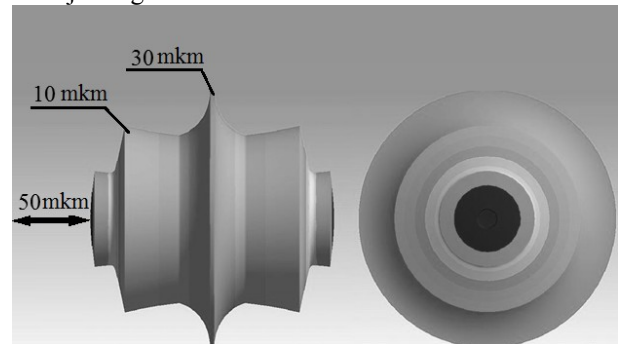

Fig. 2 – The symmetric construction with the radial junction

Carried out calculations and the results of modelling showed, that the amplitude of radial ultrasonic vibrations equaled at each point of the radiating surface.

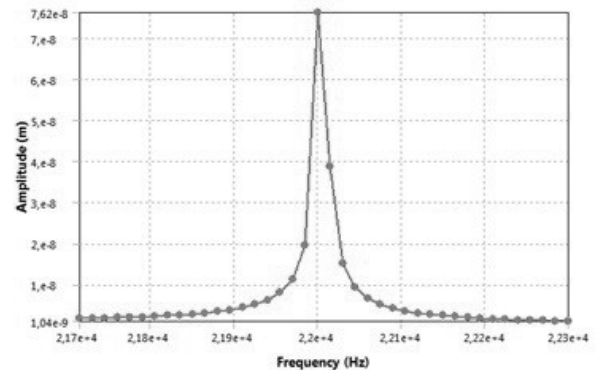

Fig. 3 – The amplitude-frequency characteristic of the symmetric construction with radial junction

The modal analysis showed, that in considered ultrasonic range the single resonance frequency existed, which corresponded to the frequency of radial vibrations.

Figure 4 presents the results of modelling of developed partly symmetric construction with the radial junction. The resonance frequency of the construction is 22 kHz.

The transformation coefficient of longitudinal vibrations into radial ones is $k=0.55$, if the width of the radiating surface is 3 mm. During the formation of continuous seams at the rotation of the working tool the maximum amplitude of radial vibrations will equal to:

$$\xi_R = \xi \times k = 50 \times 0.55 = 27 \text{ micron.} \quad (2)$$

The obtained amplitude is enough for providing of qualitative joining of welded materials.

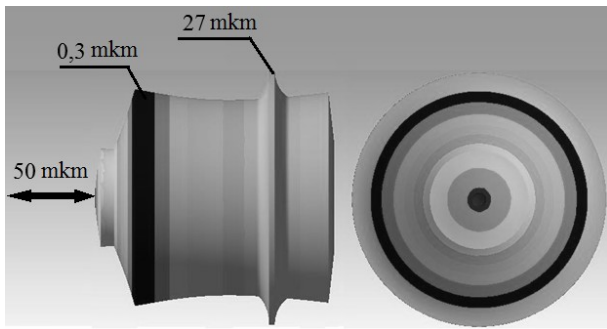

Fig. 4 – The partly symmetric construction with the radial junction

Carried out calculations and the results of modelling showed, that the amplitude of radial ultrasonic vibrations equaled at each point of the radiating surface.

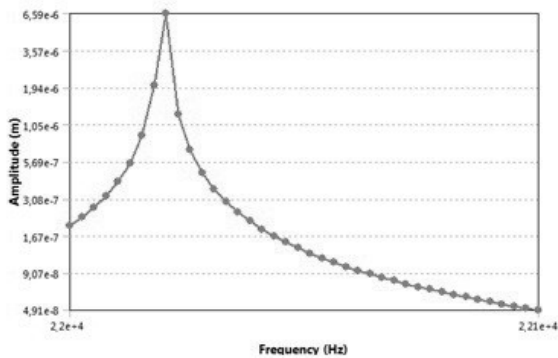

Fig. 5 – The amplitude-frequency characteristic of the partly symmetric construction with the radial junction

The modal analysis showed, that in considered ultrasonic range the single resonance frequency existed, which corresponded to the frequency of radial vibrations.

Figure 6 presents the results of modelling of developed non-symmetric construction with the radial junction. The resonance frequency of the construction is 20.7 kHz.

The transformation coefficient of longitudinal vibrations into radial ones is $k=1.5$, if the width of the radiating surface is 4 mm. During the formation of continuous seams at the rotation of of the working tool the maximum amplitude of radial vibrations will equal to:

$$\xi_R = \xi \times k = 50 \times 1,5 = 75 \text{ micron.} \quad (3)$$

The obtained amplitude is enough for providing of qualitative joining of welded materials.

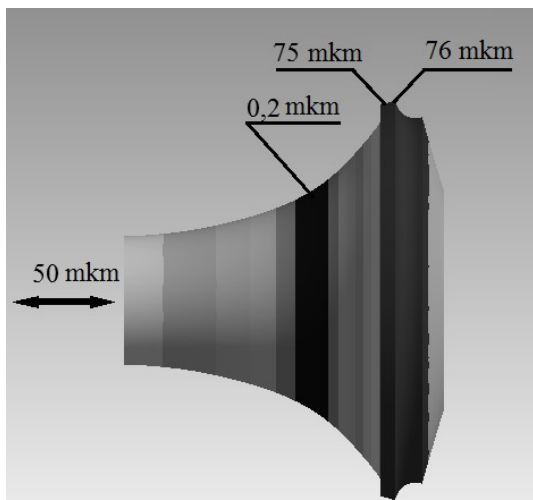

Fig. 6 – The non-symmetric construction with the radial junction

Carried out calculations and the results of modelling showed, that the amplitude of radial ultrasonic vibrations on the radiating surface along the rotation axis differed in 1 micron, that did not essentially influence on the quality of welding seam.

Figure 7 shows the drawing of the developed transducer.

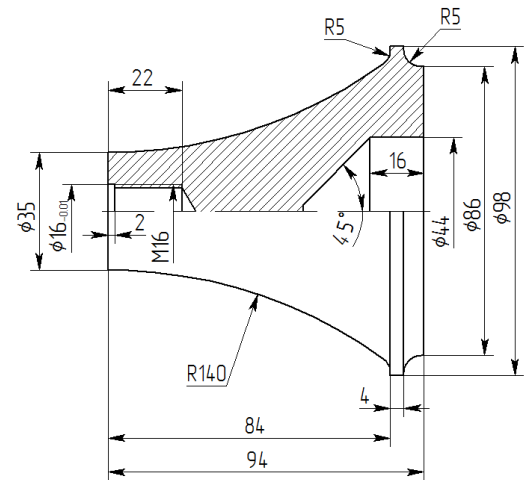

Fig. 7 – The developed transducer

This transducer provides the largest transformation coefficient, among all presented constructions, which equals to $k=1.5$. The maximum amplitude of radial vibrations, when the amplitude of longitudinal vibrations equals to 50 micron, will be 75 micron.

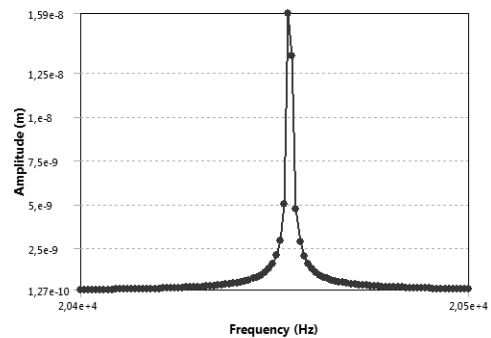

Fig. 8 – The amplitude-frequency characteristic of the non-symmetric construction with the radial junction

The modal analysis showed, that in considered ultrasonic range the single resonance frequency existed, which corresponded to the frequency of radial vibrations.

The ready-assembled ultrasonic vibrating system with the transducer of longitudinal vibrations into radial ones is shown in Figure 9.

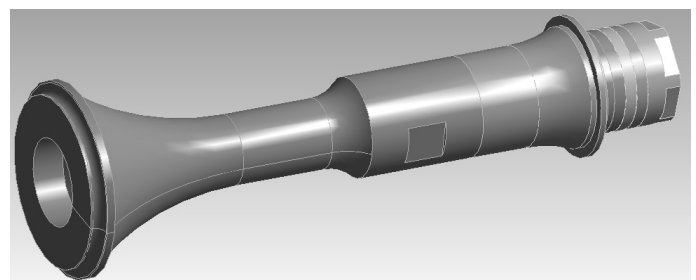

Fig. 9 – The rotating ultrasonic vibrating system

In the aggregate with the ultrasonic vibrating system (which power is 1000 W) the transducer is able to provide high productivity of the continuous welding.

V. CONCLUSION

The results of carried out researches are following:

- 1) the process of transformation of longitudinal ultrasonic vibrations into radial was studied;
- 2) different constructions of the transducers (symmetric, partly symmetric, non-symmetric) intended for continuous welding of thermoplastic materials were analyzed.
- 3) the calculations was carried out by the method of mathematical modelling and the construction of the welding tool was developed.
- 4) the developed welding tool has following parameters:
 - the resonance frequency is 20.4 kHz;
 - the transformation coefficient of longitudinal vibrations into radial ones is $k=1.5$;
 - the width of the formed welding seam is 4 mm;
 - the changes of the amplitude of radial ultrasonic vibrations on the radiating surface along the rotation axis of the transducer does not exceed 1 micron;
 - in the aggregate with the ultrasonic vibrating system (which power is 1000 W) the transducer provides the amplitude of radial vibrations of 75 micron.

REFERENCES

- [1] Kazantsev, V.F. Calculation of ultrasonic transducers for technological installations: A manual for students by correspondence courses of training engineers on the application of ultrasound in mechanical engineering [Text] I.D. Ustinov - Moscow: Machine-building, 1980. - 44s.
- [2] Kaplun, A.B., Morozov, E.M., Olfereva, M.A. ANSYS in the hands of an engineer: A Practical Guide [Text] A.B. Kaplun - Moscow: Editorial URSS, 2003. - 272.
- [3] Chigarev, A.V. ANSYS to engineers: a manual [Text] Kravchuk A.S., Smalyuk AF - Moscow: Mashinostroenie-1, 2004. - 512.
- [4] Kvashnin S.E. Training manual for the course "Medical electroacoustic systems" [text] / S.E. Kvashnin. - Moscow: Publishing House of Moscow State Technical University, 1995. - 433s.
- [5] Khmelev V.N., Barsukov R.V., Tsyganok S.N. "dimensional machining brittle and hard materials." Barnaul: Altai State Technical University, 1999
- [6] Khmelev V.N., Lebedev A.N., Tsyganok S.N., Savin I.I., Steer V.N., Khmelev M.V. "Designing of Ultrasonic Oscillation Systems for Technological Devices", Siberian Russian Workshops and Tutorials on Electron Devices and Materials EDM'2003: Workshop Proceedings. - Novosibirsk: NSTU, 2003. - p. 205-208
- [7] Symmetric ultrasonic rotary horn [Text]: patent 6457626 CIIA: MPK7 B23K 1/06, B23K 37/00, B23K 5/20 / James F.Sheehan; Sylvio J.Mainolfi (USA) patent: Branson Ultrasonic Corporation (USA) claim 09/772122 or 29.06.2001. Published: 1.10.2002
- [8] High efficiency ultrasonic rotary horn [Text]: patent 5110403 USA: MPK5 B29C 65/08 / Thomas D.Ehlert (USA) patent: Kimberly-Clark Corporation (USA) claim 526073 or 18.05.1990. Published: 5.05.1992
- [9] Structural materials [Text] / Under General Editorship. B.N. Arzamasova. - Moscow: Machine-building, 1990. - 688s.



Viktor A. Nesterov. In this time he is student of Biysk Technological Institute. IEEE Student Member.



Vladimir N. Khmelev (SM'04) - pro-rector at Biysk technological institute, professor, Full Doctor of Science (ultrasound). Honored inventor of Russia. Laureate of Russian Government premium for achievements in science and engineering. Area of scientific interests is application of ultrasound for an intensification of technological processes. IEEE member since 2000, IEEE Senior Member since 2004. His biography published in 7th issue of book "Who is who in scientific and engineering"



Alexey N. Slivin Ph.D was born in Biysk, Russia, 1976 He received degree on information measuring engineering and technologies from Altay State Technical University, key specialist of electronics. His main research interest are development of high-power electronic generators for ultrasonic technological welding.



Andrew V. Lehr was born in Barnaul, Russia, 1988 He get a higher education on information measuring engineering and technologies from Altay State Technical University. His main research interest is continuous ultrasonic seam welding of thermoplastic polymers and fabrics.